

EvoPact HVX

Vacuum Circuit Breaker up to 24 kV

User Guide

AGS531301-01_02
01/2021



USER

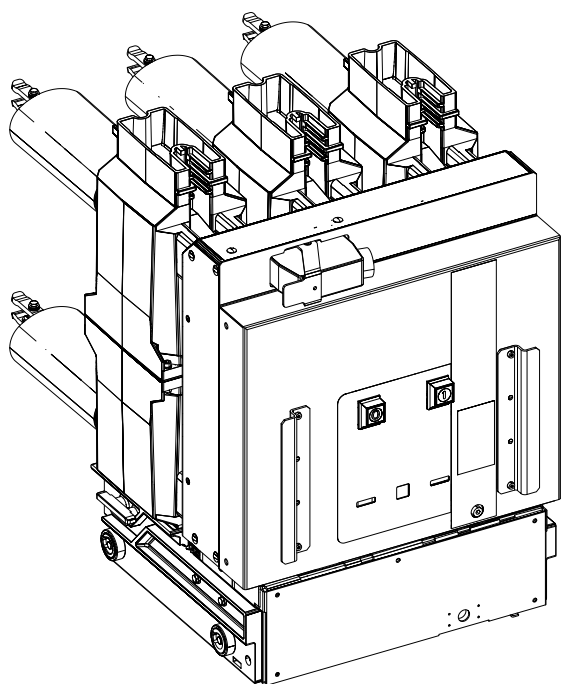

Legal Information

The Schneider Electric brand and any registered trademarks of Schneider Electric Industries SAS referred to in this guide are the sole property of Schneider Electric SA and its subsidiaries. They may not be used for any purpose without the owner's permission, given in writing. This guide and its content are protected, within the meaning of the French intellectual property code (Code de la propriété intellectuelle français, referred to hereafter as "the Code"), under the laws of copyright covering texts, drawings and models, as well as by trademark law. You agree not to reproduce, other than for your own personal, noncommercial use as defined in the Code, all or part of this guide on any medium whatsoever without Schneider Electric's permission, given in writing. You also agree not to establish any hypertext links to this guide or its content. Schneider Electric does not grant any right or license for the personal and noncommercial use of the guide or its content, except for a non-exclusive license to consult it on an "as is" basis, at your own risk. All other rights are reserved.

Electrical equipment should be installed, operated, serviced, and maintained only by qualified personnel. No responsibility is assumed by Schneider Electric for any consequences arising out of the use of this material.

As standards, specifications, and designs change from time to time, please ask for confirmation of the information given in this publication.

Pact Series

Future-proof your installation with Schneider Electric's low-voltage and medium-voltage Pact Series. Built on legendary Schneider Electric innovation, the Pact Series comprises worldclass circuit breakers, switches, residual current devices and fuses, for all standard and specific applications. Experience robust performance with Pact Series within the EcoStruxure-ready switchgear, from 16 to 6300 A in low-voltage and up to 40.5 kV in medium-voltage.



Contents

Safety Information	5
Important Information.....	5
Please Note	5
Before You Begin	6
Overall information	7
Purpose of the Document and Target Group	7
Reference documents.....	7
Abbreviations used	7
Any questions or suggestions?.....	7
Variants and technical details	8
Vacuum circuit-breaker HVX-E (truck-mounted version).....	8
Vacuum circuit-breaker HVX-F (fixed version).....	10
Dimensions	12
Applied standards.....	12
Environmental and operating conditions	12
Nameplate	13
Technical data of electrical control and operating devices	14
Packaging, transport, storage	16
Shipping units	16
Transport using a forklift truck	17
Delivery.....	17
Storage conditions	17
Assembly	18
Safety provisions and instructions for assembly.....	18
Transport using a crane	18
Mechanical assembly of the fixed version HVX-F	21
Earth terminal	23
Connecting conductor bars.....	24

Mounting the circuit-breaker HVX-E (truck-type).....	26
Connecting the control lines	28
Commissioning	29
Final steps	29
Checking switching functions and interlocks	30
Checks for the circuit-breaker HVX in conjunction with panels/switching cells	30
Operation	31
Operator interface.....	31
Operation accessories.....	32
Interlocks	33
Understanding the circuit-breaker controls and indicators	34
Charging the energy storing device.....	35
Via motor-drive	35
Switching operations.....	36
Moving truck into service / disconnected position.....	37
Maintenance	40
Safety provisions	40
Recommended maintenance program	41
Basic level preventive maintenance program to be performed every year.....	42
Cleaning insulating components.....	43
Avoiding condensation.....	43
Corrosion protection	43
Replacement of components.....	43
Lubrication instructions.....	44
Annex	47
Auxiliary products	47
Treatment of connected contact surfaces.....	47
Specifications for screw connections.....	48



Safety Information

Important Information

Read these instructions carefully and look at the equipment to become familiar with the device before trying to install, operate, service or maintain it. The following special messages may appear throughout this bulletin or on the equipment to warn of potential hazards or to call attention to information that clarifies or simplifies a procedure.



The addition of either symbol to a “Danger” or “Warning” safety label indicates that an electrical hazard exists which will result in personal injury if the instructions are not followed.



This is the safety alert symbol. It is used to alert you to potential personal injury hazards. Obey all safety messages with this symbol to avoid possible injury or death.

DANGER

DANGER indicates a hazardous situation which, if not avoided, **will result in** death or serious injury.

WARNING

WARNING indicates a hazardous situation which, if not avoided, **could result in** death or serious injury.

CAUTION

CAUTION indicates a hazardous situation which, if not avoided, **could result in** minor or moderate injury.

NOTICE

NOTICE is used to address practices not related to physical injury. The safety alert symbol shall not be used with this signal word.

Please Note

Electrical equipment should be installed, operated, serviced, and maintained only by qualified personnel. No responsibility is assumed by Schneider Electric for any consequences arising out of the use of this material.

A qualified person is one who has skills and knowledge related to the construction, installation, and operation of electrical equipment and has received safety training to recognize and avoid the hazards involved.

Before You Begin

- This user guide is meant for qualified persons who will operate the circuit breaker: panel builder, installer or end user. The generic term used in this guide for any such person is the USER.
- This user guide cannot be used to define or check the device's compatibility with every user application, nor its reliability within it. It is the duty of every user or panel builder to perform a complete risk analysis, evaluation and testing of the products in specific applications in accordance with applicable standards.
- In order to help ensure the correct functioning of the device installed in the equipment, refer to your equipment manufacturer documentation.
- When the products are used in applications with specific technical and safety rules, you must follow the integration and protection rules for the specific application.

DANGER

HAZARD OF ELECTRIC SHOCK, EXPLOSION, OR ARC FLASH

- Apply appropriate personal protective equipment (PPE) and follow safe electrical work practices. See standards or local equivalent.
- This circuit breaker must only be installed and serviced by qualified electrical personnel.
- Perform work only after reading and understanding all of the instructions contained in this guide.
- Turn off all power supplying this circuit breaker before working on or inside the circuit breaker. Turn off or trip the circuit breaker and discharge the mechanism.
- Always use a properly rated voltage sensing device to confirm power is off.
- Replace all devices, covers and doors before turning on power to this circuit breaker.
- Beware of potential hazards and carefully inspect the work area for tools and objects that may have been left inside the circuit breaker.
- Do not modify the mechanical or electrical parts.
- Do not operate the system with interlocks and safety barriers removed.

Failure to follow these instructions will result in death or serious injury.

CAUTION

HAZARD OF DEGRADED EQUIPMENT PERFORMANCE

- Respect the handling rules and avoid any shocks to the device.
- Perform the maintenance and servicing operations described in the maintenance section of this guide.
- Observe the normal service conditions described in this guide.
- If the circuit breaker, or the equipment in which the circuit breaker is mounted, is stored before its final installation, observe the storage conditions.

Failure to follow these instructions can result in injury or equipment damage.



Overall information

As our products are subject to continuous further development, we reserve the right to make changes regarding standards, illustrations and technical data.

All dimensions specified in this manual are in millimeters.

Purpose of the Document and Target Group



This Technical Manual describes transport, assembly, operation and maintenance of the EvoPact HVX vacuum circuit-breakers. It is exclusively intended for specialist electricians who have been certified for the EvoPact HVX (training certificate).

This Technical Manual is an integral part of the product and must be kept accessible at all times to persons performing assembly, operation of or maintenance on the circuit-breaker. If the circuit-breaker is sold to new owners, they must receive this document along with the switching device.

This Technical Manual cannot describe every imaginable individual case or every customer-specific version of the product. For information which is not included in this manual, please contact the manufacturer.

Reference documents

The following additional documents must be complied with:

- Purchase agreement with the stipulations regarding the switch-specific equipment and the legal details
- Switch-specific circuit diagrams and documentation
- Project notes regarding the HVX circuit breaker

For assembly and operation of the circuit-breaker, the operating manual of the switchgear in which it is operated must be complied with.

Abbreviations used

HVX-F: HVX circuit-breaker for fixed mounting

HVX-E: HVX circuit-breaker for truck-mounting

U_r : Rated voltage

I_r : Rated current

I_{sc} : Rated short-circuit breaking current

Any questions or suggestions?

Do you have any questions or suggestions regarding this manual, or do you require further information?

We always strive to provide you with the best-possible information for optimum, safe use of our products. Thus, do not hesitate to contact us if you have any recommendations, amendments or proposals for improvement.

Variants and technical details



Vacuum circuit-breaker HVX-E (truck-mounted version)

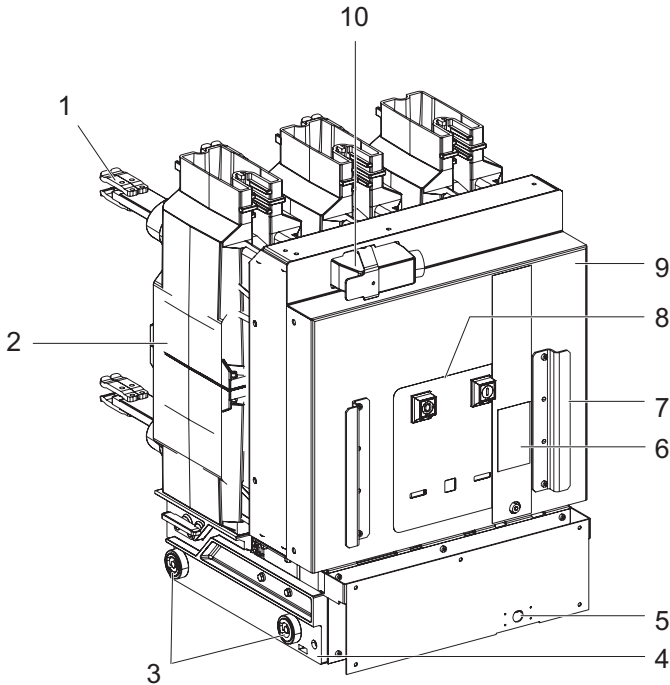

Rated voltage U_r	[kV]	12
Rated lightning impulse withstand voltage U_p	[kV]	75
Rated power frequency withstand voltage U_d	[kV]	28
Rated normal current I_r	[A]	≤ 1250
Rated short-circuit breaking current I_{sc}	[kA]	≤ 25
Rated short-time withstand current I_k (3 s)	[kA]	≤ 25
Rated frequency f_r	[Hz]	50/60
Weight (without packaging)	[kg]	approx. 135

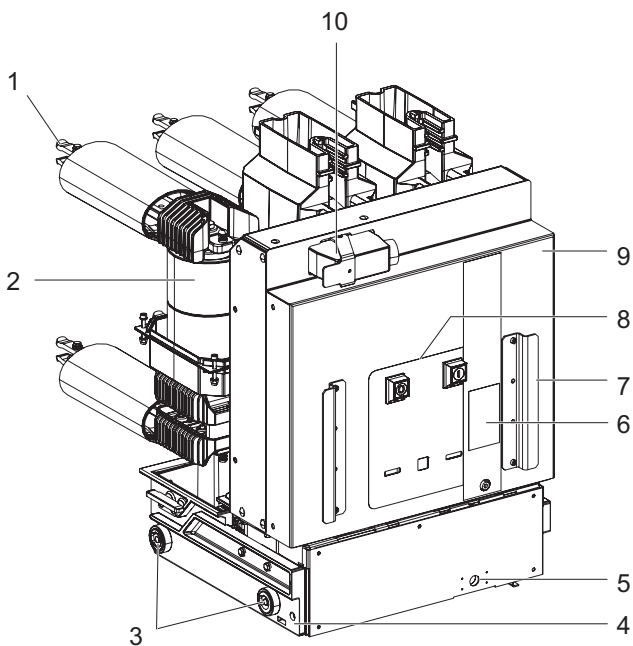

Rated voltage U_r	[kV]	24
Rated lightning impulse withstand voltage U_p	[kV]	125
Rated power frequency withstand voltage U_d	[kV]	50
Rated normal current I_r	[A]	≤ 2500
Rated short-circuit breaking current I_{sc}	[kA]	≤ 40
Rated short-time withstand current I_k (3 s)	[kA]	≤ 40
Rated frequency f_r	[Hz]	50/60
Weight (without packaging)	[kg]	approx. 160

Fig. 1 Models of the vacuum circuit-breaker HVX-E

- | | |
|--|--|
| 1 Moving contacts | 6 Nameplate |
| 2 Vacuum interrupter chambers | 7 Handles |
| 3 Rollers | 8 Operator interface |
| 4 Truck for PI-, PIB- and PIX panels | 9 Drive casing |
| 5 Insertion opening for crank to move the circuit-breaker into its disconnected/service position | 10 Low-voltage connector for control lines |

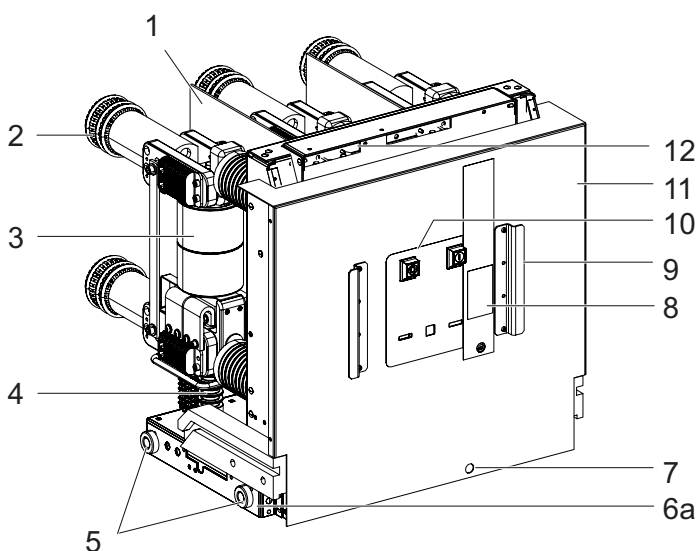

Rated voltage U_r	[kV]	17.5
Rated lightning impulse withstand voltage U_p	[kV]	95
Rated power frequency withstand voltage U_d	[kV]	38
Rated normal current I_r	[A]	≤ 3150 4000 ¹
Rated short-circuit breaking current I_{sc}	[kA]	≤ 50
Rated short-time withstand current I_k (3 s)	[kA]	≤ 50
Rated frequency f_r	[Hz]	50/60
Weight (without packaging)	[kg]	approx. 330

¹ with fan in PIX standard panel

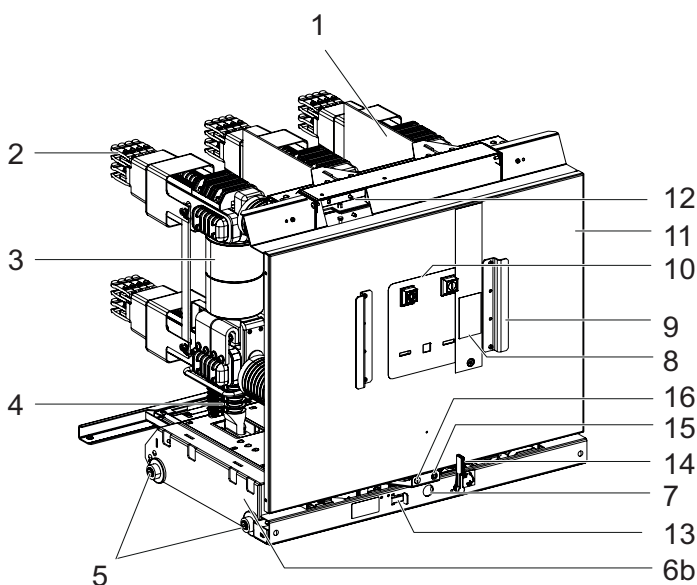

Rated voltage U_r	[kV]	17.5
Rated lightning impulse withstand voltage U_p	[kV]	95
Rated power frequency withstand voltage U_d	[kV]	38
Rated normal current I_r	[A]	≤ 3150 4000 ² 5000 ²
Rated short-circuit breaking current I_{sc}	[kA]	≤ 50
Rated short-time withstand current I_k (3 s)	[kA]	≤ 50
Rated frequency f_r	[Hz]	50/60
Weight (without packaging)	[kg]	approx. 135

² with fan in PIX High panel

Fig. 2
Models of the vacuum circuit-breaker HVX-E

- | | |
|--|--|
| 1 Pole partitions | 9 Handles |
| 2 Moving contacts | 10 Operator interface |
| 3 Vacuum interrupter chambers | 11 Drive casing |
| 4 Press rod (transfer of ON/OFF switching movement) | 12 Low-voltage connector for control lines |
| 5 Transport rollers | 13 Slide for opening the insertion opening (7) for racking the truck in and out manually |
| 6a Truck for PIX panels | 14 Lever for locking/unlocking the truck in the panel |
| 6b Truck for PIX High panels | 15 Position indicator - truck in service position |
| 7 Insertion opening for crank to move the circuit-breaker into its disconnected/service position | 16 Position indicator - truck in disconnected position |
| 8 Nameplate | |

Vacuum circuit-breaker HVX-F (fixed version)

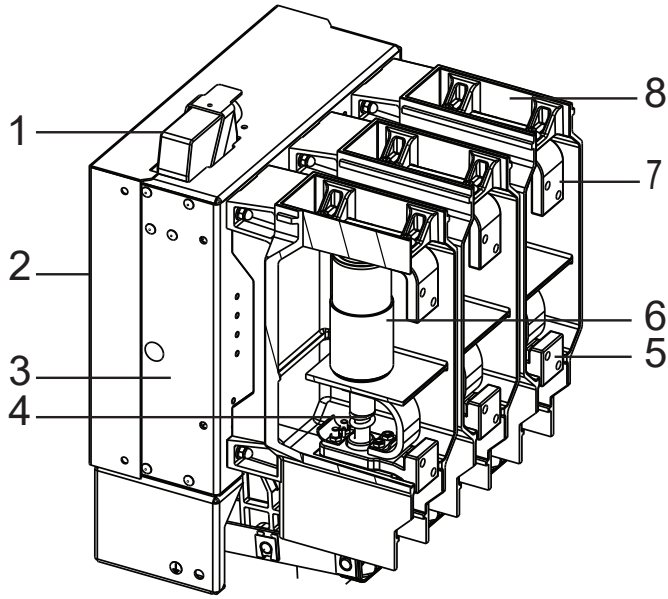

Rated voltage U_r	[kV]	12
Rated lightning impulse withstand voltage U_p	[kV]	75
Rated power frequency withstand voltage U_d	[kV]	28
Rated normal current I_r	[A]	≤ 1250
Rated short-circuit breaking current I_{sc}	[kA]	≤ 25
Rated short-time withstand current I_k (3 s)	[kA]	≤ 25
Rated frequency f_r	[Hz]	50/60
Weight (without packaging)	[kg]	approx. 135

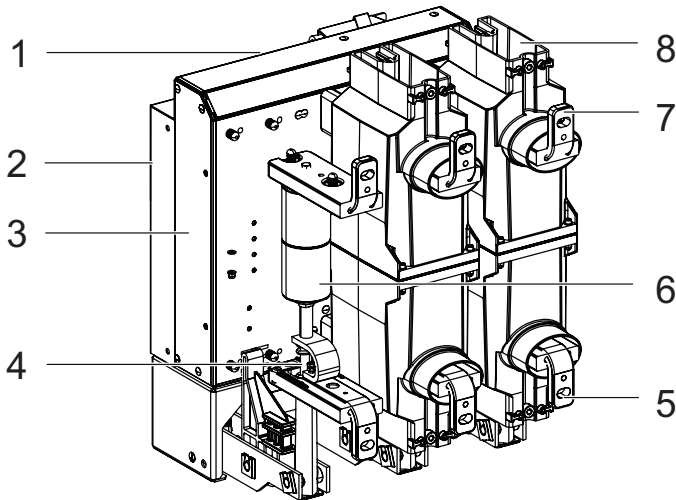

Rated voltage U_r	[kV]	24
Rated lightning impulse withstand voltage U_p	[kV]	125
Rated power frequency withstand voltage U_d	[kV]	50
Rated normal current I_r	[A]	≤ 2500
Rated short-circuit breaking current I_{sc}	[kA]	≤ 40
Rated short-time withstand current I_k (3 s)	[kA]	≤ 40
Rated frequency f_r	[Hz]	50/60
Weight (without packaging)	[kg]	approx. 160

Fig. 3
Models of the vacuum circuit-breaker HVX-F

- | | |
|--|-------------------------------------|
| 1 Low-voltage connector for control lines | 4 Drive mechanism for pole sections |
| 2 Front control panel (not visible in this illustration) | 5 High-voltage connection, bottom |
| 3 Drive casing | 6 Vacuum interrupter chambers |
| | 7 High-voltage connection, top |
| | 8 Pole section |

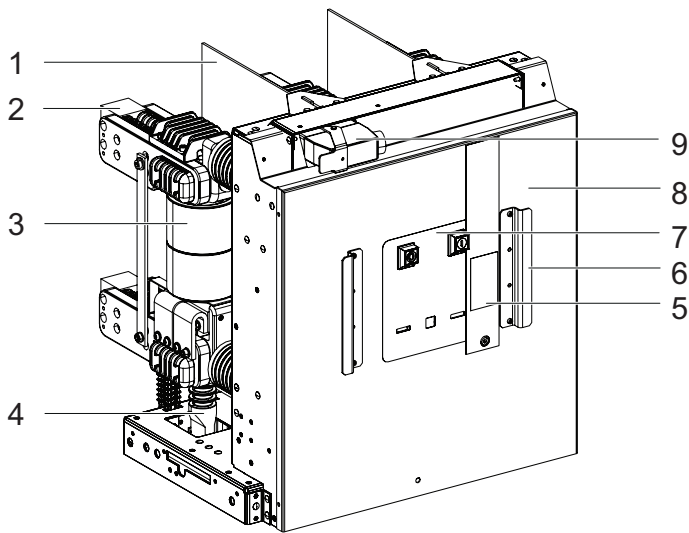

Rated voltage U_r	[kV]	17.5
Rated lightning impulse withstand voltage U_p	[kV]	95
Rated power frequency withstand voltage U_d	[kV]	38
Rated normal current I_r	[A]	3150 4000 ¹
Rated short-circuit breaking current I_{sc}	[kA]	≤ 50
Rated short-time withstand current I_k (3 s)	[kA]	≤ 50
Rated frequency f_r	[Hz]	50/60
Weight (without packaging)	[kg]	approx. 230

¹ with fan (available on request from the manufacturer)

Fig. 4
Models of the vacuum circuit-breaker HVX-F

- | | |
|---|---|
| 1 Pole partitions | 5 Nameplate |
| 2 Conductor bar terminal | 6 Handles |
| 3 Vacuum interrupter chambers | 7 Operator interface |
| 4 Press rod (transfer of ON/OFF switching movement) | 8 Drive casing |
| | 9 Low-voltage connector for control lines |

Dimensions

The dimensions of the individual HVX variants are specified in the selection list HVX. This document or additional customized dimensional drawings are available on request.

Applied standards

EvoPact HVX circuit-breakers are

- type-tested
- dimensioned for indoor installation

EvoPact HVX circuit-breakers meet the following standards and regulations

Designation	IEC standard
High-voltage switchgear and controlgear - Part 1: Common specifications	IEC 62271-1
Circuit-breaker	IEC 62271-100
Disconnecter truck	IEC 62271-102

Regarding the switching capacity and the insulation level, the EvoPact HVX complies with the following ANSI specifications:

- ANSI C37.04
- ANSI C37.06
- ANSI C37.09

Type approval of vacuum interrupter chambers acc. to. RöV

The vacuum interrupter chambers have been approved by the X-Ray Ordinance (RöV) of the Federal Republic of Germany up to a maximum voltage amounting to the rated short-time power-frequency voltage (rated power frequency withstand voltage) defined by DIN VDE/IEC. Thus, they satisfy the conditions for operation exempt of approval up to the voltage in question according to the X-Ray Ordinance (RöV).

Environmental and operating conditions

HVX circuit-breakers may only be operated under normal operating conditions acc. to IEC 62271-1. Operation under conditions deviating from these is only admissible upon consultation with and with the written approval of the manufacturer.

(Ambient conditions in accordance with IEC 62271-1)		
Temperature class		"Minus 5 indoors" ¹
Min./max. ambient temperature	°C	-5/+40 ¹
Average value over 24 hours	°C	≤ 35 ¹
mean rel. air humidity: 24 hour/1 month	%	≤ 95/≤ 90
Installation altitude above sea-level	m	≤ 1000 ¹

¹ other values available on request

Nameplate

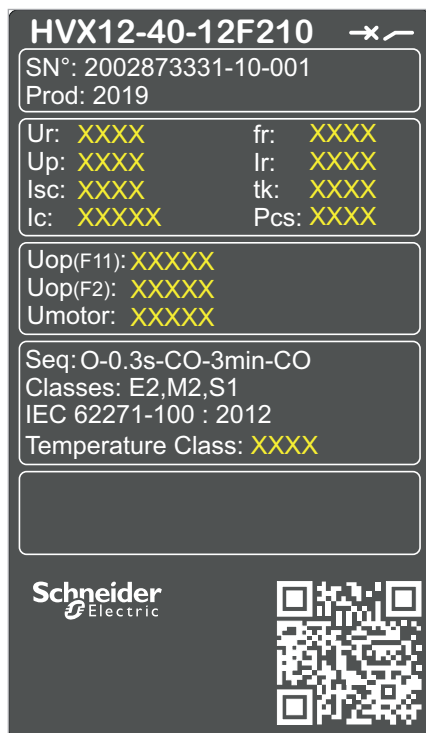

Fig. 5
Nameplate

Commercial reference

SN	: Serial number
Ur	: Rated voltage
Up	: Rated lightning impulse withstand voltage
lsc	: Rated short-circuit breaking current
lc	: Rated cable-charging breaking current
fr	: Rated supply frequency of closing and opening devices
lr	: Rated normal current
tk	: Rated duration of short circuit
Pcs	: D.C. component
Uop(F11)	: Tripping coil
Uop(F2)	: Closing coil
Umotor	: Rated supply voltage of motors
Seq	: Rated operating sequence
Rated frequency	
Classes	: Classes of electrical endurance, of mechanical endurance and of system Standard with date of issue

QR code

How to use the QR code

The serial number (SN) located on the nameplate uses 18 characters in order to be easy to understand. Example: SE-2016-W44-5-0014.

The QR code located on the nameplate grants access to all data relating to your circuit breaker, from a Smartphone or a connected tablet:

- serial number
- user guide
- ...

To access this information, read the QR code with your smartphone or your connected tablet; you will be directed to the website containing the data relating to your device. Follow the instructions to obtain personal access.

The serial number and the commercial reference also allow access to the information without Smartphone or connected tablets.

Technical data of electrical control and operating devices

The circuit-breaker (Q0) and the truck versions (Q1) have been designed on principle for manual operation. The drive mechanisms can be equipped, depending on the specific customer's model, with additional electrical control and operating devices. These are defined in the switch-specific circuit diagram (see separate documentation).

Component fitting options:

- Motor (M1)
 - for charging the energy-storing device
 - HVX-E: electric actuation of the disconnecter truck
- Shunt closing release (F2)
 - 1 pce.
- Shunt tripping coil (F11/F12/F13)
 - 3 ea. max.
- Secondary release (transformer-operated release) (F31/F32/F33)
 - 3 ea. max.
- Undervoltage release (F4)
 - 1 pce.
- Blocking coil (Y1)
 - Blocking coils prevent the circuit breaker from being closed and opened via the push-buttons "ON" or "OFF", as well as manual actuation of the disconnecter truck.
 - If the rated supply voltage has failed or is shut off, all blocking coils are in "blocked" position.
- Auxiliary switch for circuit-breaker ON/OFF position (S11/S12/S13)
 - Auxiliary switches are always actuated directly by the switch shaft via an intermediate linkage. Their position always corresponds to that of the main contacts. The circuit breaker is equipped as standard with S11 / S12 auxiliary switches, as option S13.
 - The switching functions have been set in the factory according to the wiring diagram.
- Micro switch actuated by energy-storing device (S2)
- Micro switch actuated by ON/OFF push-button (S41/42)
- Micro switch actuated by OFF pushbutton (S43)
- Micro switch actuated by truck in intermediate position or by crank being inserted (S6)

The circuit-breaker (Q0) and the truck versions (Q1) can be equipped with additional micro switches, depending on customers' design.

- Anti-pumping relay (K01)
 - If an ON and OFF command is simultaneously and permanently present at the circuit-breaker, the latter returns to its initial position after closing. It remains in this initial position until the ON command is issued again. This prevents continuous closing and opening ("pumping").
- Terminal strip (X01)

Overview of rated supply voltages

Overview of rated supply voltages							
Direct voltage DC	[V]	24	48	60	110	125	220
Alternating voltage AC	[V]	(110)/120			(220)/230		

Technical data of the electrical releases and motors

Solenoids / motor	Power consumption [W]	
	DC [W]/AC 50/60 Hz [VA]	
Rated normal current [A]	≤2500	>2500
Closing release	≤ 250	
Opening release	≤ 250	
Undervoltage release	approx. 12	
Motor for energy-storing device	approx. 100	approx. 150
Motor for disconnecter truck	approx. 120	<200
Secondary release	approx. 12 (AC)	

Information about the power consumption of solenoids and the motor is available from the manufacturer. The supply voltage data is required to this effect.

Times for solenoids and motor		
Minimum command time "OFF" el. tripping	[ms]	20
Minimum command time "ON" el. tripping	[ms]	20
Motor charging time for energy storing device	[s]	≤ 12

Technical data of the auxiliary switches on the circuit-breaker

Rated supply voltage	[V]	DC [V]			AC [V]	
		≤ 48	125	220	120	230
Switching capacity	[A]	10	3.8	1	10	
Rated short-time current		250 A / 3 s				
Time constant T = L/R	[ms]	10		20	–	
Rated continuous current	[A]	15			–	

Technical data of auxiliary switches on the disconnecter truck for PIX High panels

Rated supply voltage	[V]	DC [V]					AC [V]	
		24	48	60	110	220	120	230
Switching capacity	[A]	8	4	3	2	1	10	
Rated short-time current		100 A/30 ms						
Time constant T = L/R	[ms]	≤ 20						
Rated continuous current	[A]	10						

Packaging, transport, storage



Shipping units

- The conditions and types of transport have been stipulated in the contract details. The type of packaging depends on the type of transport and the storage conditions.
- The circuit-breakers are delivered ready for connection. The accessories are included.

Packaging

- If packed exclusively for truck transport, the circuit-breakers are delivered, depending on their outside dimensions, either
 - in cardboard boxes and delivered on a pallet (Fig. 6),
 - directly fixed to the pallet and packed in PE protective film,
 - delivered in wooden crates with PE protective film (Fig. 7).
- For sea transport, the units are packed in sealed aluminium foil with desiccant and in a closed wooden case with tightly closed wooden base (also for container transport).
- In case of air transport, the panels are packaged in wooden crates with a protective PE film hood (dust protection) or in wooden crates, also with closed wooden bases, however without protective hoods (dust protection, Fig. 7).



Fig. 6
Packed in cardboard box on a pallet

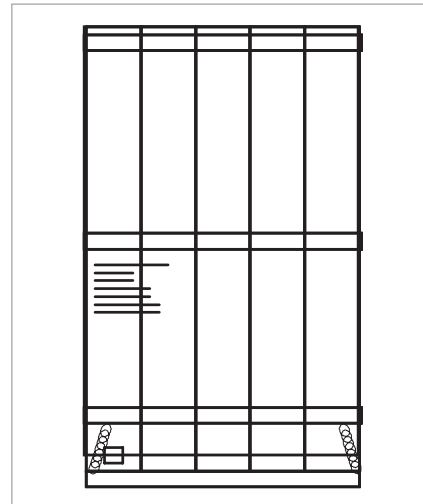

Fig. 7
Packed in a wooden case

Transport using a forklift truck

Move packing unit only complete with pallet. Move the forks completely under the whole pallet. The circuit-breaker must be fixed safely on the pallet.

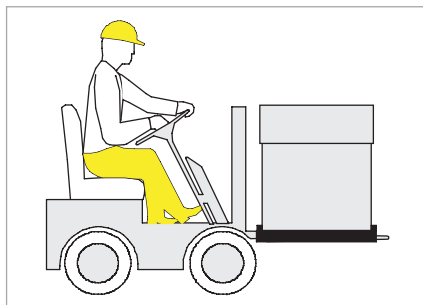

Fig. 8
Transport using a forklift truck

Delivery

- Handle shipping units carefully when unloading and unpacking them.
- Shipping units must be checked upon receipt. Any damage which may have occurred in transit must be recorded and reported to the manufacturer immediately.
- Check completeness of consignment based on the transport documents. The supplier must be notified in writing without delay about any possible deviations.

Storage conditions

⚠ CAUTION

HAZARD OF UNINTENDED DEVICE OPERATION

- If the device is to be stored, observe all storage instructions. The device must remain in the packaging until the final installation.
- Never install the device if damaged.

Failure to follow these instructions can result in injury or equipment damage.

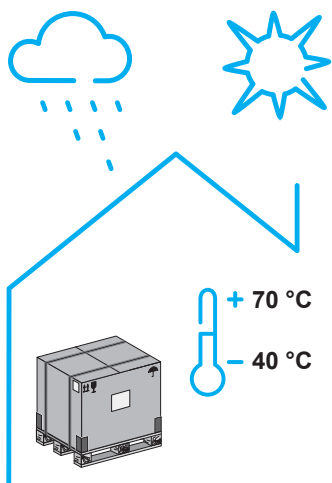

In order to preserve all of the device characteristics when stored for prolonged periods, Schneider Electric recommends storing the device in its original packaging, in dry conditions, and sheltered from the sun and rain at a temperature of between -40°C and $+70^{\circ}\text{C}$.

The maximum storage period is 12 months.

If the device was stored:

- between 6 and 12 months, perform basic level preventive maintenance to help ensure a correct device operation.
- beyond 12 months, contact your Schneider Electric Service local representative for device check-up.

After unpacking, check the device carefully for:

- absence of broken or damaged parts
- absence of condensation marks or droplets
- absence of visible degradation (color change, rust, deposits, for example).

In case of any degradation detected, the circuit breaker must not be installed.

Assembly



Safety provisions and instructions for assembly

⚠ WARNING
<p>CRUSH HAZARD Do not charge the circuit-breaker’s energy-storing device during assembly.</p> <p>Failure to follow these instructions can result in death, serious injury, or equipment damage.</p>

The circuit-breakers may only be assembled and installed by the manufacturer’s staff or by persons who have been certified for this work.

The circuit-breakers are delivered in circuit-breaker position "OFF" and with the energy storing device "released".

Instructions for assembly

- For all screw connections which are not specified directly in the assembly description, use the tightening torques mentioned in “Specifications for screw connections”, page 48.
- Check technical data on nameplate.
- Dimension drawings are provided on request.
- Any other than standard installation positions must be agreed upon with the manufacturer.
- Screws, bolts and attachments are not included in the scope of supplies.
- Parts designed for fastening must be suitable for the weight of the circuit-breaker.
- The circuit-breaker must not be deformed by the fastening.

Transport using a crane

⚠ WARNING
<p>HAZARD OF FALL OR TIPPING OF THE DEVICE DURING UNLOADING OR HANDLING</p> <ul style="list-style-type: none"> • Apply appropriate personal protective equipment (PPE) and provide collective protection equipment (CPE) whenever required. Follow all safe work practices. • Do not try to catch the parcel if it falls. • Use handling equipment suitable for the dimensions and weight of the device. • Take into account the position of the center of gravity when handling the parcels or the device. <p>Failure to follow these instructions can result in death, serious injury, or equipment damage.</p>

⚠ CAUTION
<p>HAZARD OF DEVICE FALLING</p> <p>Move the device with the utmost caution and avoid shocks.</p> <p>Failure to follow this instruction can result in injury or equipment damage.</p>

For crane transport, a crane mounting harness with a rope (not a metallic steel cable) with a diameter of Ø 12–15 mm or a strap is used. The specified weight must be complied with.

HVX model designed for $U_r \leq 24 \text{ kV}$, $I_r \leq 2500 \text{ A}$, $I_{sc} \leq 40 \text{ kA}$

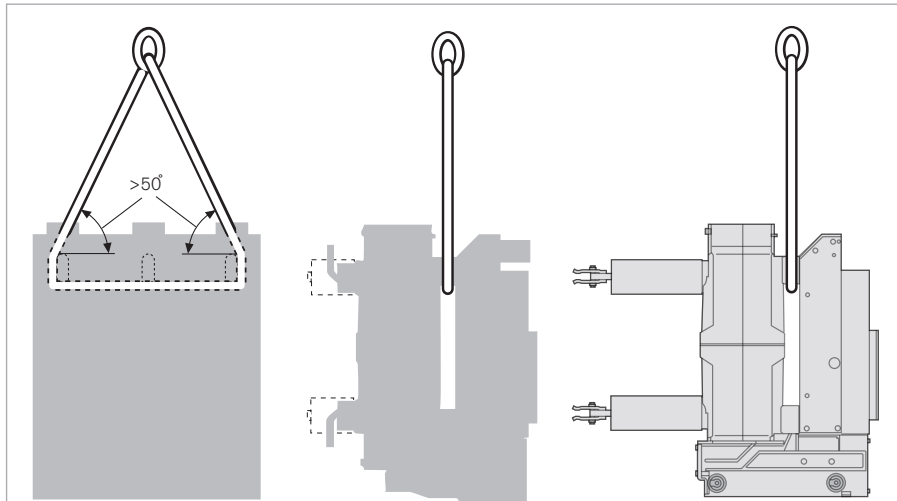

Fig.10
Transport by means of a crane



HVX model designed for $U_r \leq 17.5$ kV, $I_r \leq 3150$ A, $I_{sc} \leq 50$ kA**NOTICE****HAZARD OF GUIDE ROLLERS DEFORMATION**

Position circuit-breaker with guide rollers on the truck on wooden bars or rails.

Failure to follow this instruction can result in equipment damage.

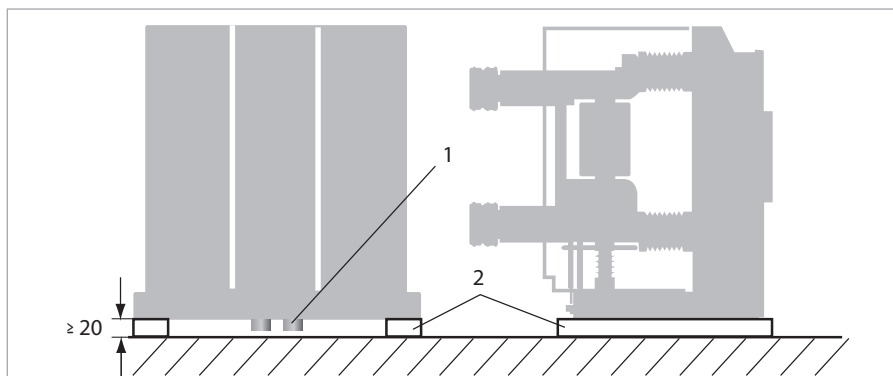
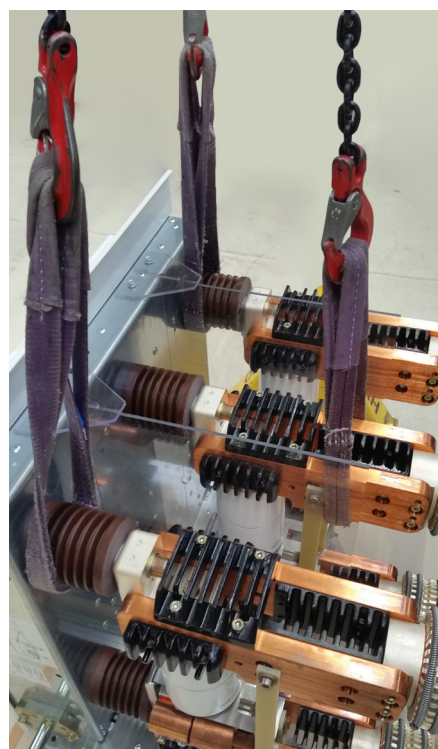
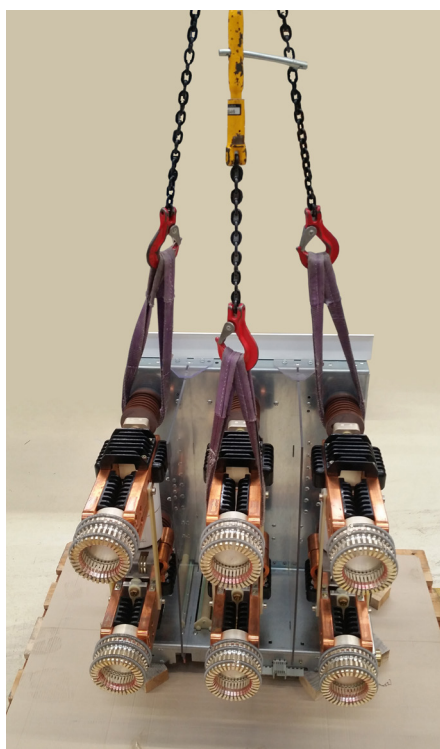

Fig. 11

Transport by means of a crane

- 1 Guide rollers (only on truck with pole center spacing 254)
- 2 Wooden bars or rails as a support



Mechanical assembly of the fixed version HVX-F

The circuit-breakers shown below are protected against overturning by a transport support (U section rail on the central circuit-breaker pole) (Fig. 12). Unscrew transport support after or - if required - during assembly.

Remove the transport support

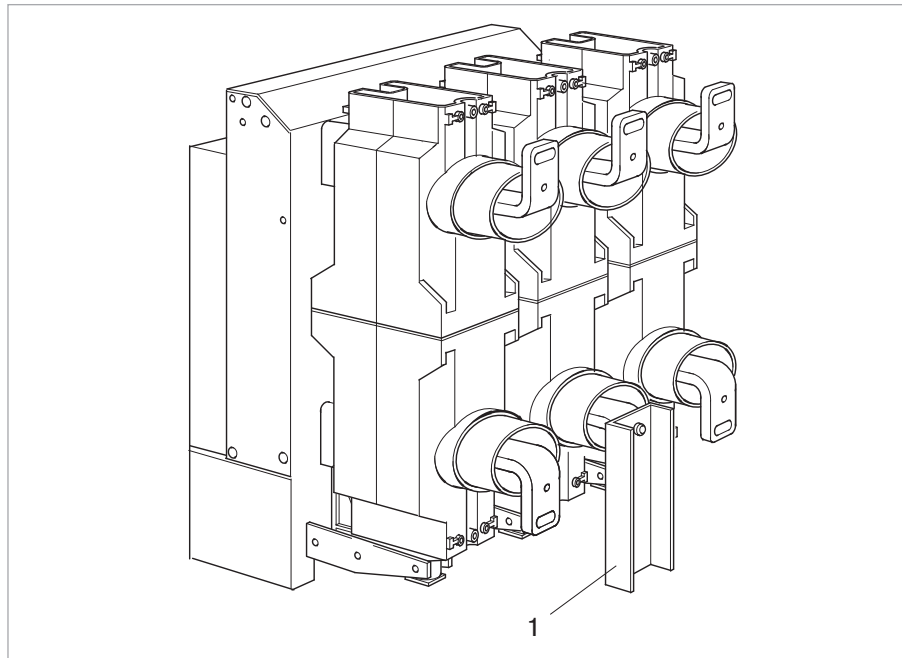

Fig. 12
1 Transport support

For fastening, the circuit-breaker HVX-F features 4 bore-holes with a \varnothing of 12.5 mm. Fasten the circuit-breaker to the frame below the drive casing using 4 screws M 10 (Fig. 13).

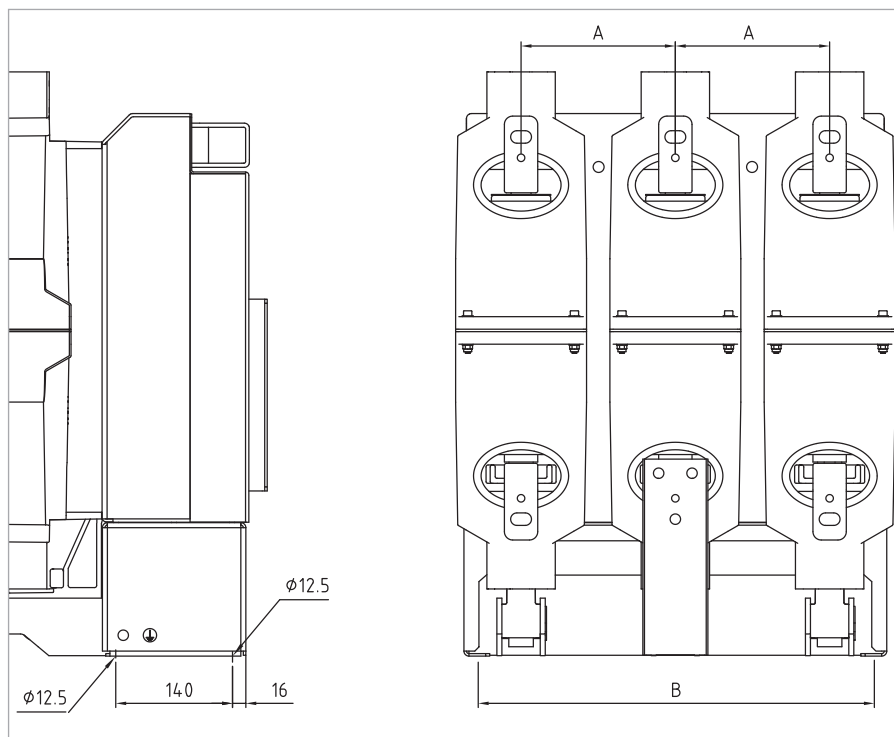
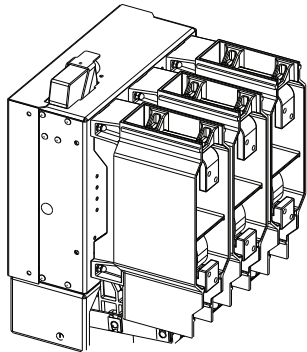
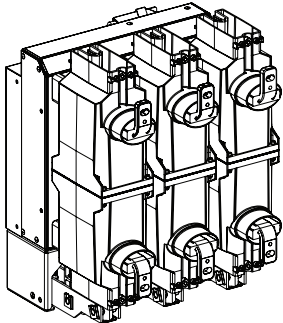

Fig. 13
Dimension drawing of the fastening points on circuit-breakers HVX-F for rated normal current $I_r \leq 2500$ A

Version HVX-F		Pole center distance A [mm]	Distance between fastening bore-holes B [mm]
Model designed for $U_r \leq 12 \text{ kV}$ $I_r \leq 1250 \text{ A}$ $I_{sc} \leq 25 \text{ kA}$		150	408
		210	534
Model designed for $U_r \leq 24 \text{ kV}$ $I_r \leq 2500 \text{ A}$ $I_{sc} \leq 40 \text{ kA}$		165	471
		185	471
		210	534
		275	664

Fastening the circuit-breaker HVX-F dimensioned for $I_r \leq 3150 \text{ A}$, $I_{sc} \leq 50 \text{ kA}$

The circuit-breaker cannot be fastened using an L rail (not included in scope of supplies) (Fig. 14). Fastening points are the lateral bore-holes ($\varnothing 13$) in the lower circuit-breaker housing. A dimensional drawing is provided on request. Please clarify further technical details with the manufacturer.

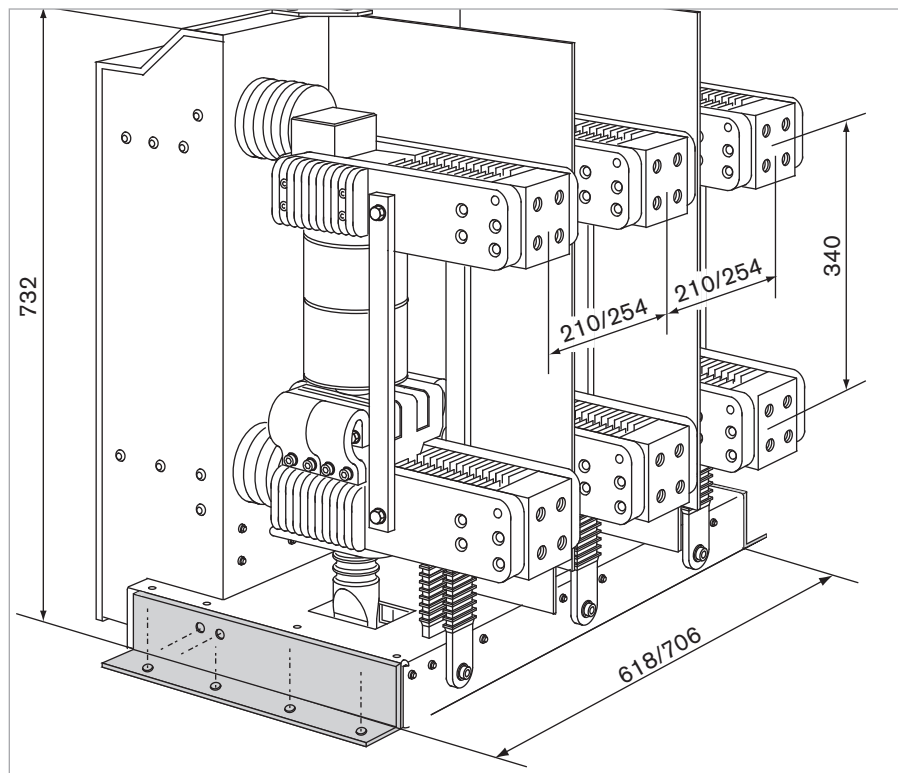

Fig. 14
 Dimensions and fastening points of the circuit-breaker HVX-F with $I_r \leq 3150 \text{ A}$, $I_{sc} \leq 50 \text{ kA}$

4 bore-holes for fastening are provided in the base plate of the rack for M12 screw connections.

Earth terminal

NOTICE

HAZARD OF OVERHEATING

Treat contact surfaces and comply with specified tightening torques.

Failure to follow this instruction can result in equipment damage.

Earthing devices are not included in the scope of supplies.

Design and dimensioning of the earth terminal for the circuit-breaker in accordance with IEC 62271-100.

The mechanical fastening of the circuit-breaker (see “Mechanical assembly of the fixed version HVX-F”, page 21) is simultaneously used to earth the circuit-breaker.

Additional earth connection

Additionally, both sides of the rack of the smaller fixed-type versions feature bore-holes \varnothing 12.5 mm for a further earth terminal (Fig. 15).

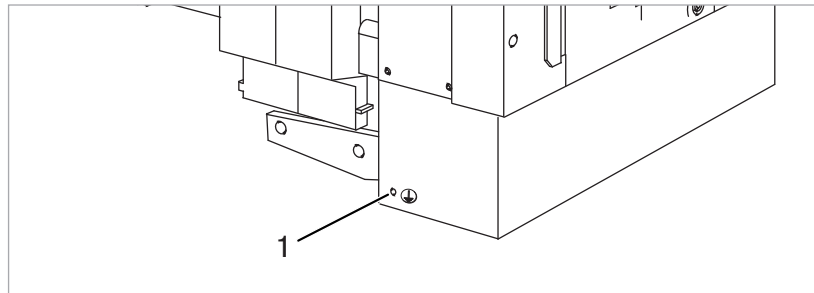

Fig. 15

1 Earth terminal \varnothing 12.5 (on both sides) on circuit-breakers HVX-F with rated normal current $I_r \leq 2500$ A

Connecting conductor bars

NOTICE

HAZARD OF OVERHEATING

Treat contact surfaces and comply with specified tightening torques.

Failure to follow this instruction can result in equipment damage.

Material of connection surfaces

Rated normal current I_r	Connection areas	
	on circuit-breaker	on the conductor bar
630 A	Copper, metallicly bright	Copper
> 630 A	Copper, silver-plated	Copper or copper, silver-plated

Note for connection of the conductor bars or cables:

- Adjust conductor bars so that after screw-fastening, no mechanical forces are acting on the circuit-breaker.
- Conductor bars must be dimensioned sufficiently according to the specifications for rated and short-circuit current. National standards must be complied with.
- In case of short-circuit current, make sure that the circuit-breaker pole is not exposed to higher electrodynamic forces. The connecting bars must be provided with sufficient support in the vicinity of the circuit-breaker connectors.

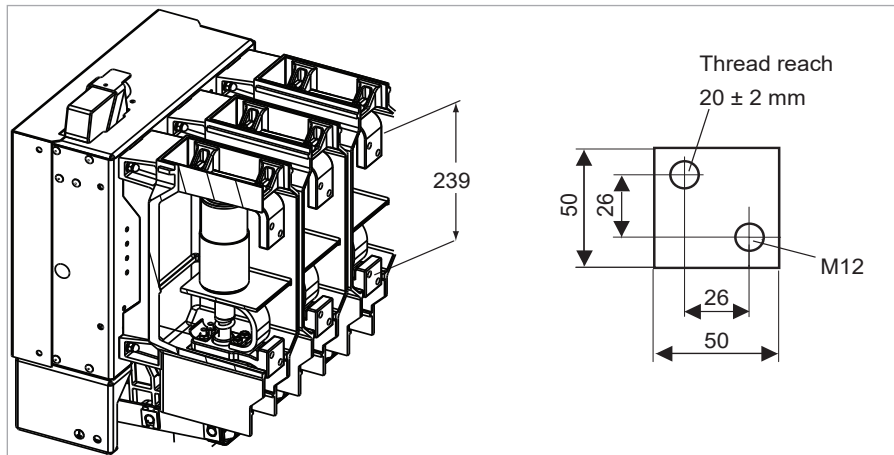

Fig.16 High-voltage terminal of circuit-breaker HVX-F ($U_r \leq 12$ kV, $I_r = 1250$ A, $I_{sc} \leq 25$ kA)

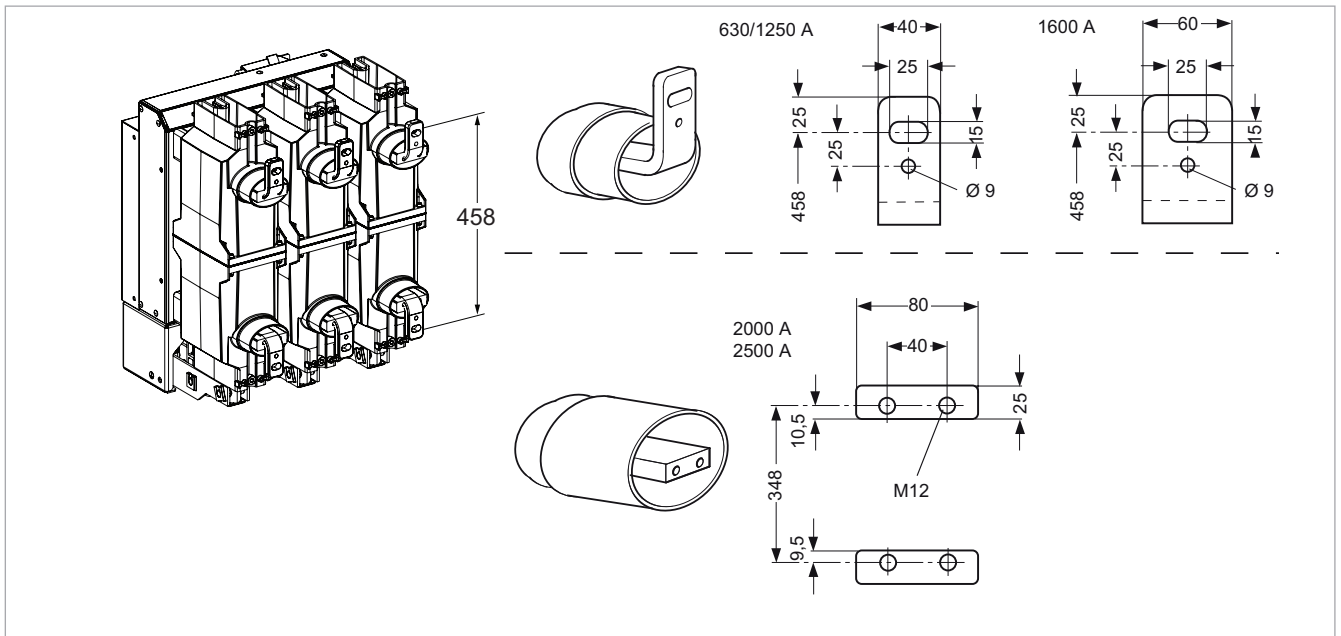

Fig. 17
 High-voltage terminal for fixed mounting HVX-F ($U_r \leq 24$ kV, $I_r \leq 2500$ A, $I_{sc} \leq 40$ kA)

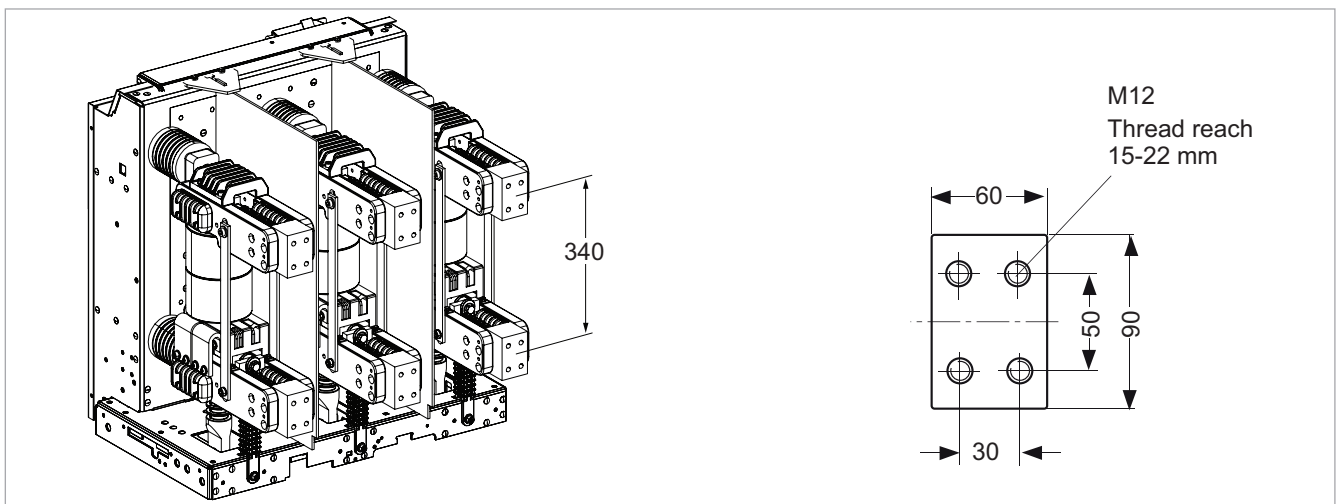

Fig. 18
 High-voltage terminal of circuit-breaker HVX-F ($U_r \leq 17.5$ kV, $I_r \leq 3150$ A, $I_{sc} \leq 50$ kA)

Mounting the circuit-breaker HVX-E (truck-type)

A transport trolley must be used for racking the circuit-breaker into the panel (Fig. 19 and Fig. 20). The transport trolley depends on the panel type and is not included in the scope of supplies. For the design and method of operation of the transport trolley used, please refer to the instructions for the panel in question.

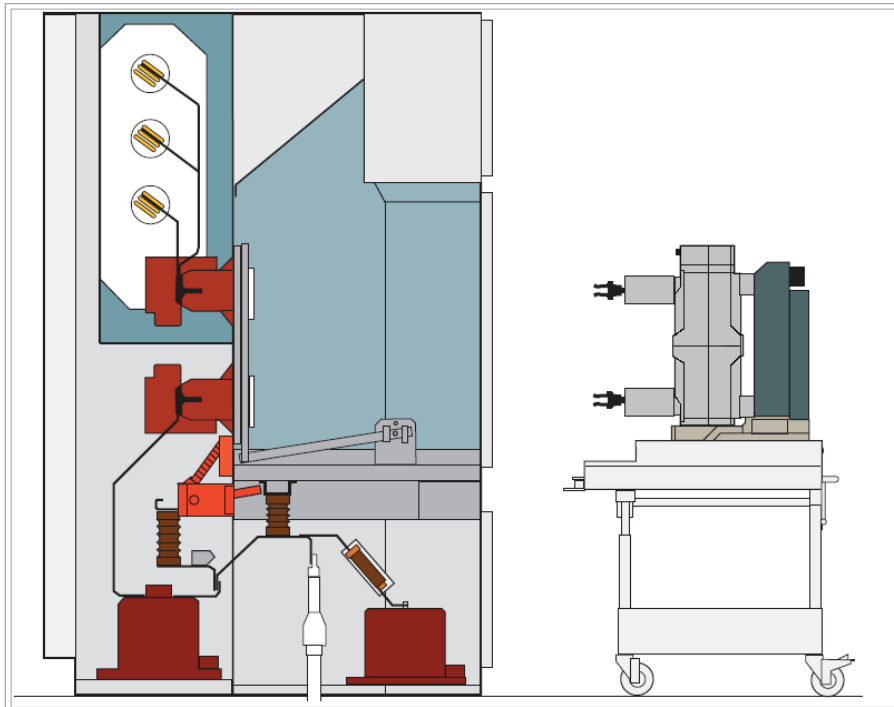

Fig. 19
Circuit-breaker HVX-E (≤ 40 kA) on transport trolley in front of the panel PIX Standard

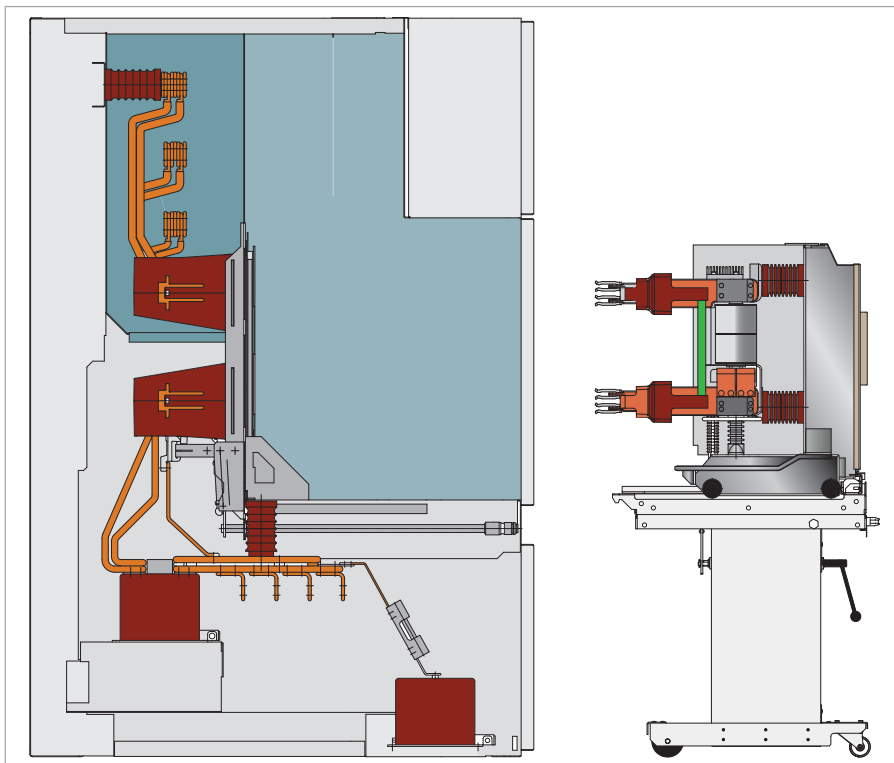

Fig. 20
Circuit-breaker HVX-E (50 kA) on transport trolley in front of the panel PIX High

Placing circuit-breaker on transport trolley and racking it into the switchgear

⚠️ DANGER

HAZARD OF PLACING THE CIRCUIT BREAKER IN THE WRONG PANEL

When performing the following assembly steps, observe and comply with the instructions given for the panel used.

Failure to follow these instructions will result in death or serious injury.

1. Check the ratings indicated on the nameplate of the HVX-E against those of the appropriate panel.
2. Place the circuit-breaker on the transport trolley rails.
3. Lock the circuit-breaker on the transport trolley.
4. Couple the transport trolley to the panel.
5. Unlock the circuit-breaker from the transport trolley. Push the circuit-breaker into the panel.
 - The HVX trucks must latch in the lock rockers of the panels (Fig. 21).
 - HVX trucks for PIX High Panels are anchored in the panel by actuation of the truck interlock (Fig. 22).
6. Release the transport trolley from the panel.

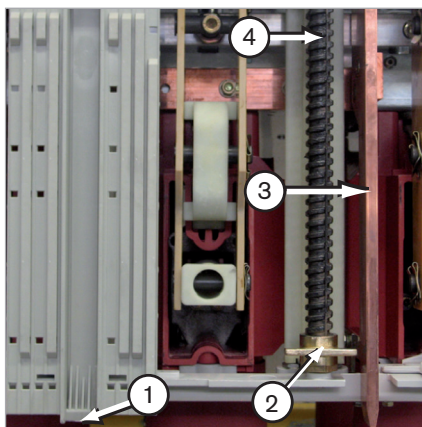

Fig. 21
HVX-E underside

- 1 Circuit-breaker coding
- 2 Spindle nut of truck (must be latched in the cell)
- 3 Earth bar (optional)
- 4 Spindle of disconnector truck

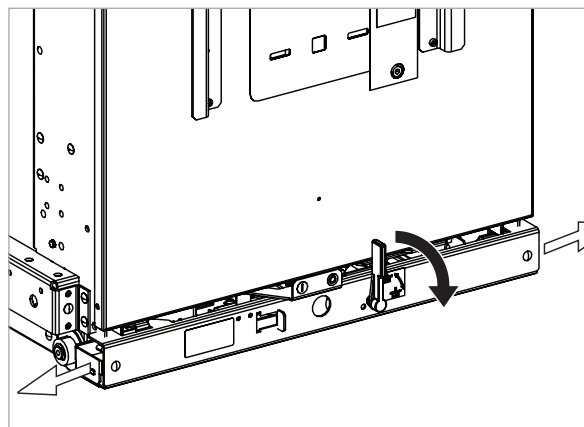

Fig. 22
Truck interlock in PIX High panel

Earth terminal

The equipotential bonding connection of the circuit-breaker and the panel is effected via the two front truck rollers (Fig. 23).

The HVX-E circuit-breaker is optionally available with short-circuit proof earthing (Fig. 21 item 3 and Fig. 24).

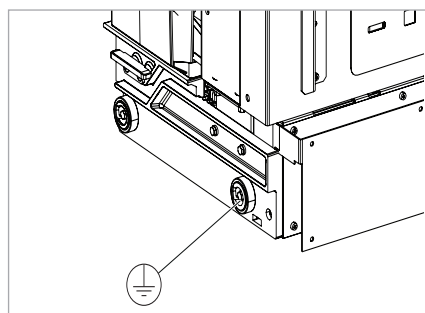

Fig. 23
Equipotential bonding in the cell above the truck rollers

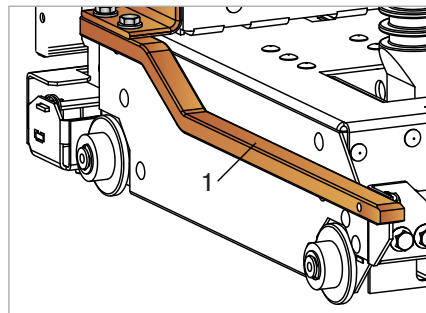

Fig. 24
1 Earth bar on circuit-breaker HVX-E for PIX High panels

Connecting the control lines

The control lines are connected, depending on design, via control connectors (Fig. 25, Fig. 26, Fig. 27 and Fig. 29) or via control lines to the terminal strips in the drive casing (Fig. 28 and Fig. 29). The control lines are wired in the circuit-breaker up to the control connector or up to the terminal strip.

Single-wire conductors or strands can be connected

- on terminal strip, up to 2.5 mm²
- in the control connector, up to 1.5 mm².

Connection via control connector

Push the control connector onto the 64-(36-) pin right-angle plug-and socket connector of the circuit-breaker, and lock it (Fig. 25, Fig. 26, Fig. 27 and Fig. 29).

Note: Connector interlock of HVX-E: The control connector on the cell end can only be inserted or removed while the circuit-breaker is in disconnected position.

Connection to terminal strip

1. Remove the cover plate.
2. Connect external control lines via the terminal strip (Fig. 28 and Fig. 29). The switch-specific circuit diagram (electric diagram) is enclosed with each circuit-breaker and must be observed during connection.
If additional control lines are laid in the drive casing, keep a sufficient distance from moved parts of the drive.
3. After connecting the external control lines, mount the cover plate.

HVX dimensioned for $U_n = 12-24 \text{ kV}$

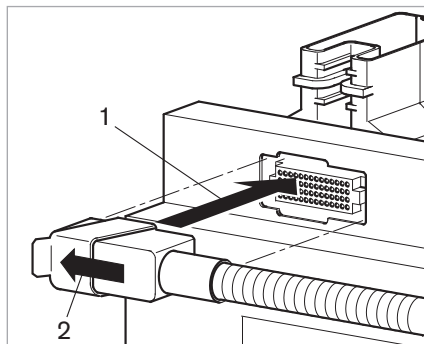

Fig. 25
Control connector, 64-pole
1 Insert control connector
2 Lock

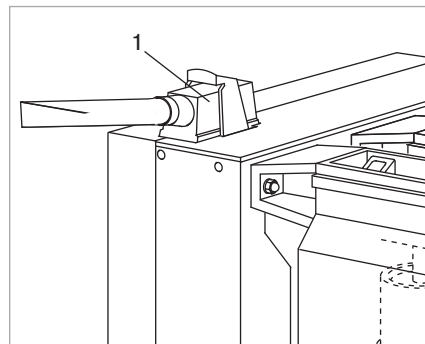

Fig. 26
1 Control connector, 64-pole

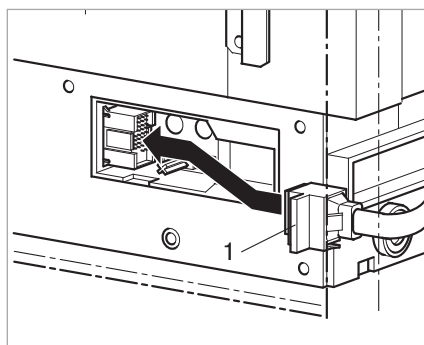

Fig. 27
1 Insert control connector, 36-pole

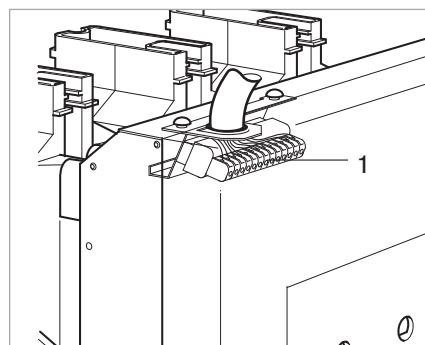

Fig. 28
1 Control line connector on terminal strip

Commissioning



Final steps

DANGER

HAZARD OF ELECTRIC SHOCK, EXPLOSION, OR ARC FLASH

- Perform all the checks with the entire switchboard de-energized.
- Check that nameplate data is compatible with that of electrical installation.
- Check the correct operation of the auxiliary releases.

Failure to follow these instructions will result in death or serious injury.

Checking assembly

- Check securing bolts.
- Check the conductor bars' screw connections using a torque wrench.
- Check the screw connections of the earth terminal.
- Check wiring laid on site.

Damaged paint

Minor damage to the paint can be repaired using a commercially available touch-up pen (standard colour RAL 7044 or corresponding colour) (see "Auxiliary products", page 47).

Inspection

- Check the circuit-breaker for damage which might be due to transport or assembly work.
- Compare the data on the nameplate (see "Nameplate", page 13) to the required rating specifications.
- Check rated supply voltage of control and operating devices.
- Check surfaces of insulating components for impurities. If necessary, clean (see "Cleaning insulating components", page 43).

Checking switching functions and interlocks

⚠ ⚠ DANGER
<p>HAZARD OF ELECTRIC SHOCK, EXPLOSION, OR ARC FLASH</p> <ul style="list-style-type: none"> • Perform all the checks with the entire switchboard de-energized. • Check the correct operation of the auxiliary releases. <p>Failure to follow these instructions will result in death or serious injury.</p>

⚠ CAUTION
<p>CRUSH HAZARD</p> <ul style="list-style-type: none"> • Do not put your hand or fingers in the mechanism. • Check that the front cover is in place. <p>Failure to follow this instruction can result in injury or equipment damage.</p>

For switching operations, comply with Chapter "Operation", page 31.

In case supply voltage is not available:

- Blocking coils (optional; lock circuit-breaker button and/or truck in disconnected position) are in locked position, thus blocking manual switching operations.
- There is a dropped-out undervoltage release in the circuit-breaker (optional).

Checking switching functions and interlocks

1. Charge energy-storing device using the crank. Check position indicator on the circuit-breaker.
2. Apply supply voltage.
3. Switch circuit-breaker on and off several times manually.
Check position indicator.
4. Move truck to its operating and disconnected positions via the crank (only HVX-E). Check mechanical interlocks between the HVX-E and the cell. Check position indication.
5. Check electrical functions of control and operating devices:
 - Closing and opening releases for circuit-breaker
 - Optional motor-operated drives for the truck (only HVX-E)
6. Check switch position indicators and interlocks (Chapter "Operation", page 31).

Checks for the circuit-breaker HVX in conjunction with panels/ switching cells

Verification of the required ratings and performance characteristics

Before commissioning, panels or switching cells must be qualified completely with the switching devices installed by means of type tests in acc. with IEC 62271-200/IEC 62271-1 or national regulations.

If the circuit-breaker HVX is used in panels or switching cells which have not yet been qualified together, type tests in acc. with IEC 62271-200 and IEC 62271-1 or national regulations must be performed.

Operation



Operator interface

HVX Circuit-breaker dimensioned for $U_r = 12-24 \text{ kV}$

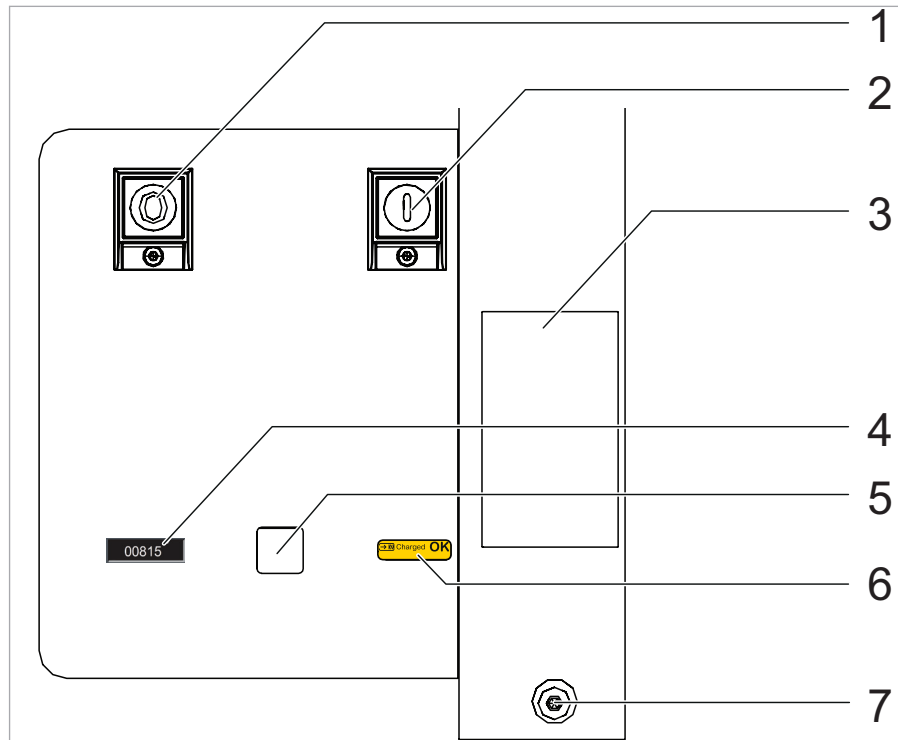

Fig. 29

Operating interface of HVX circuit-breaker with a rated voltage of 12-24 kV

- 1 OFF button (rocker "0")
- 2 ON button (rocker "I")
- 3 Nameplate
- 4 Operation counter
- 5 Position indicator of circuit breaker
- 6 Position indicator of spring mechanism
- 7 Insertion opening for charging the closing spring

Operation accessories

Position (Fig. 30)	Designation	Ref. no.
1	Operating rod for ON/OFF actuation	AGS H35 446-01
2	Spring charging crank for energy-storing device	AGS H30 498-01
3	Moving crank handle with integrated slip coupling for disconnecter truck (HVX-E)	AGS H31 601-01 ¹
		AGS H32 532-01 ²
		AGS H31 674-01 ³
4	Moving crank handle for disconnecter truck in PIX High panels	AGS C66 911-01

¹ Disconnecter truck, manually actuated, shape of insertion opening: hexagonal

² Disconnecter truck, manually actuated, shape of insertion opening: square

³ Emergency crank handle for disconnecter truck, motor-actuated

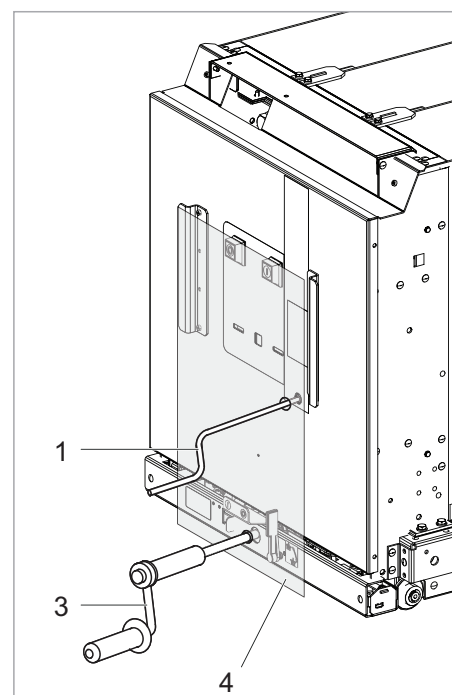
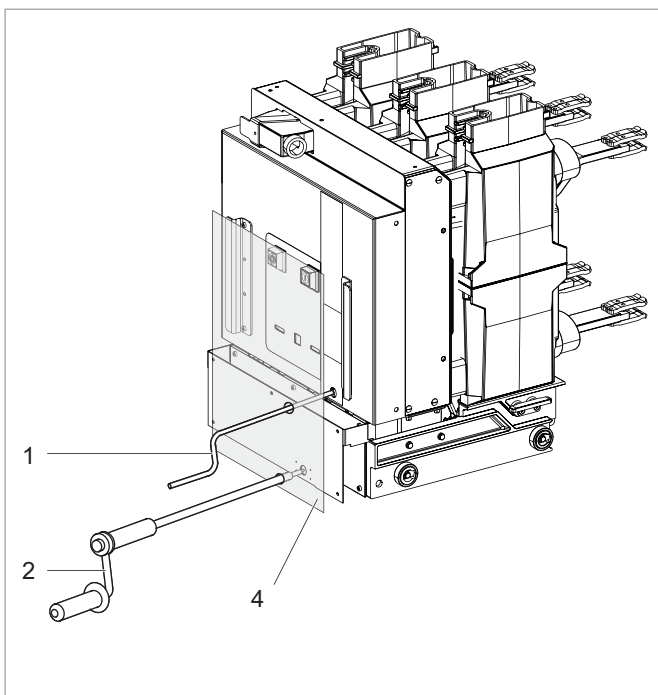

Fig. 30

Accessories for circuit-breaker HVX-F and HVX-E

- 1 Spring charging crank for energy-storing device
- 2 Moving crank handle with integrated slip coupling for disconnecter truck (HVX-E)
- 3 Moving crank handle for disconnecter truck in PIX High panels
- 4 Closed door of switchgear panel

Interlocks

⚠️ ⚠️ DANGER

HAZARD OF ELECTRIC SHOCK, EXPLOSION, OR ARC FLASH

- Always keep the circuit breaker compartment door closed when racking the device in service position.
- When the circuit breaker is connected to the main power circuit, always use the controls with the circuit breaker compartment door closed.

Failure to follow these instructions will result in death or serious injury.

Electromagnetic interlocks (optional)

The manual operating facilities on the circuit-breaker can be locked optionally by blocking coils. Electromagnetic blocking coils can be used for inter-panel as well as intra-panel interlocks:

- The circuit-breaker’s ON and OFF pushbuttons are blocked.
- The insertion opening for the crank to move the circuit-breaker into its disconnected/service position is blocked (only for HVX-E).

Note: In case of failure of the auxiliary supply voltage, all electrical interlocks are in their “locked” position.

Mechanical interlocks in the HVX-E

The circuit-breaker HVX-E (truck) features mechanical basic interlocks to prevent operating errors:

Interlock	Function of interlock	Method of operation of interlock
Between truck and low-voltage connector	The truck cannot be racked in unless the low-voltage connector is inserted and locked.	The opening for the moving crank handle is locked.
	The low-voltage connector can only be inserted or removed while the truck is in its disconnected position.	The interlock for the low-voltage connector on the drive end has been activated.
Between the truck and the operating state of the circuit-breaker	Circuit-breaker cannot be racked in or out while it is switched on	The opening for the moving crank handle is locked.
	Circuit-breaker cannot be switched on unless <ul style="list-style-type: none"> – it is completely in its disconnected or service position and – the operating crank for the racking-in mechanism has been removed. 	The circuit-breaker cannot be switched ON or OFF.

Understanding the circuit-breaker controls and indicators

⚠ ⚠ DANGER

HAZARD OF ELECTRIC SHOCK, EXPLOSION OR BURN

- Installation, repair and maintenance work on the device must only be carried out by qualified personnel.
- Beware of potential danger, apply appropriate personal protective equipment and take appropriate safety precautions.

Failure to follow these instructions will result in death or serious injury.

Circuit breaker indicators		Electrical state	State description	Command available
Main contacts position indicator	Spring charged and ready-to-close indicator			
			Circuit breaker is OPEN and mechanism is discharged.	Charging the mechanism
			Circuit breaker is OPEN. Mechanism is charged but the circuit breaker cannot be CLOSED.	None Check conditions for «ready to close» state
			Circuit breaker is OPEN with mechanism charged and circuit breaker is «ready to close».	Closing of the circuit breaker
			Circuit breaker is CLOSED and mechanism is discharged.	<ul style="list-style-type: none"> • Charging the mechanism • Opening the circuit breaker
			Circuit breaker is CLOSED and mechanism is charged.	Closing of the circuit breaker

Charging the energy storing device

Initial position:

- Circuit-breaker in “OFF” position
- Energy storing device released

Manually

1. Insert crank into opening for tensioning the energy storing device (Fig. 31).
2. Turn clockwise, until the charge drive mechanism is uncoupled (sound). The energy storing device indicates the “charged” condition.
3. Remove crank. The circuit-breaker is ready for closing.

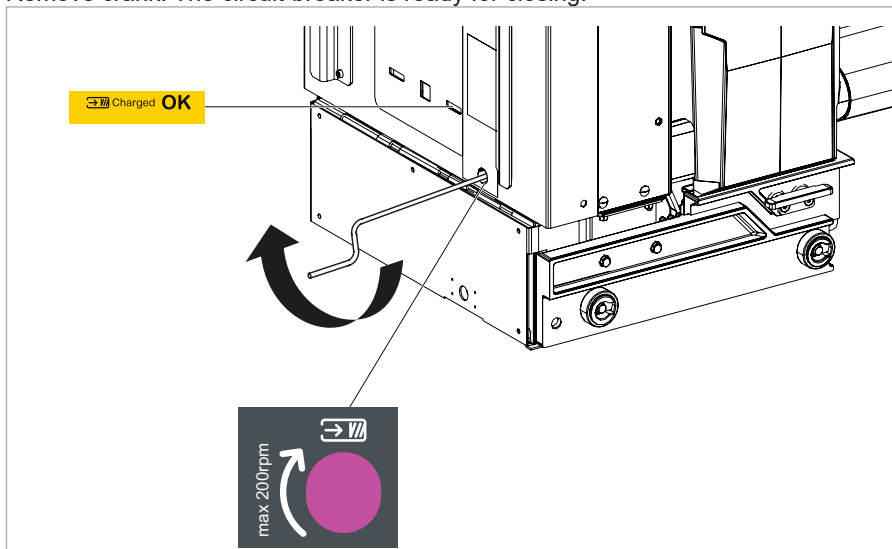

Fig. 31
Charging the energy storing device manually

Via motor-drive

The energy storing device of motorized circuit-breakers is charged automatically as soon as the supply voltage is applied.

Switching operations

NOTICE

HAZARD OF CIRCUIT BREAKER NOT OPERATING PROPERLY

Do not press the button more than 1 second.

Failure to follow this instruction can result in equipment damage.

All available versions for switching the circuit-breaker ON and OFF are listed below. Depending on the switch-specific equipment, versions may be shown, but not be available.

Switching ON (Closing)

- Press ON button (1) or
- actuate closing release electrically.

Position indicator indicates the "ON" position (2).

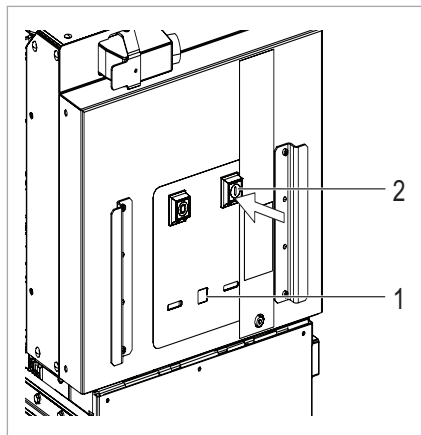

Fig. 32

- 1 Switching ON via pushbutton
- 2 Position indicator indicates "ON"

Note: Remove this tool after each switching operation for which you have used a crank or a lever.

The energy storing device can be charged again immediately after switching ON (manually or by motor). If voltage is applied to the motor, charging is performed automatically. The position indicator shows the energy storing device position "charged".

Switching OFF (Opening)

- Press OFF button (O) by means of the operating rod or
- Press OFF button (O) or
- actuate opening release electrically, or
- by undervoltage release or secondary release

The position indicator indicates the switch position OFF.

Moving truck into service / disconnected position

⚠️ ⚠️ DANGER

HAZARD OF ELECTRIC SHOCK, EXPLOSION, OR ARC FLASH

- Operate the truck in isolated or deenergized condition.
- Switch off the circuit breaker before operating the truck.

Failure to follow these instructions will result in death or serious injury.

Initial situation:

- Circuit-breaker OFF

Racking-in the truck from disconnected into service position

The crank features an integrated slip coupling which prevents damage to the drive mechanism due to an excessive torque. The slip coupling can react if the truck is moved to its final stop in disconnected or service position.

1. Open cover in panel (Fig. 33, item 1) and insert crank (2).
2. Turn crank clockwise (3) until the truck has been racked in. Remove crank.
3. Check position of the truck (Fig. 34) through the inspection port.

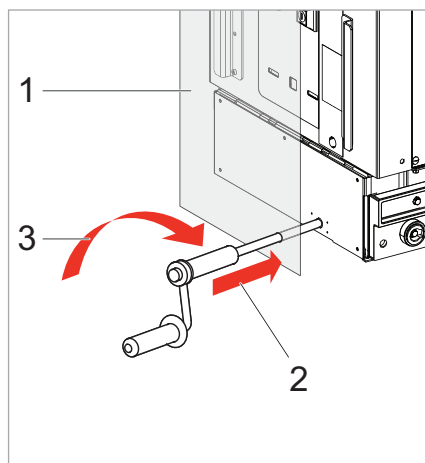

Fig. 33

- 1 Open panel cover
- 2 Insert crank
- 3 Turn crank clockwise

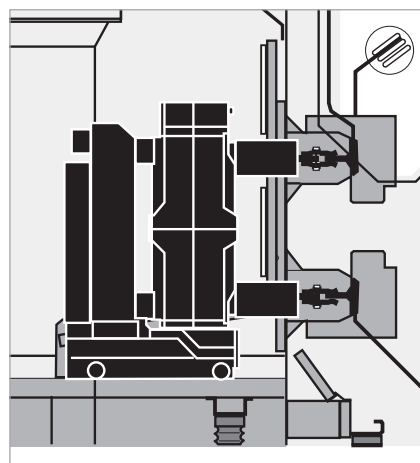

Fig. 34

Truck in service position

Racking-out the truck from service into disconnected position

1. Open cover in panel (Fig. 35, item 1) and insert crank (2).
2. Turn crank counter-clockwise (3) until the truck has been racked out. Remove crank.
3. Check position of the truck (Fig. 36) through the inspection port.

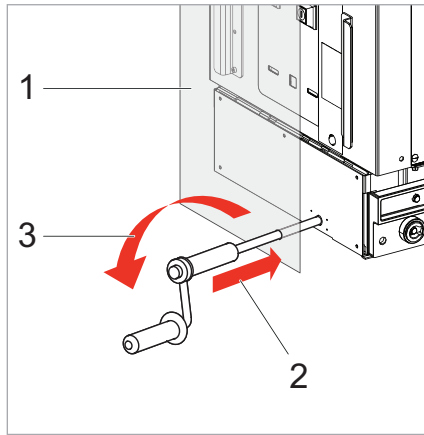

Fig. 35
1 Open panel cover
2 Insert crank
3 Turn crank counter-clockwise

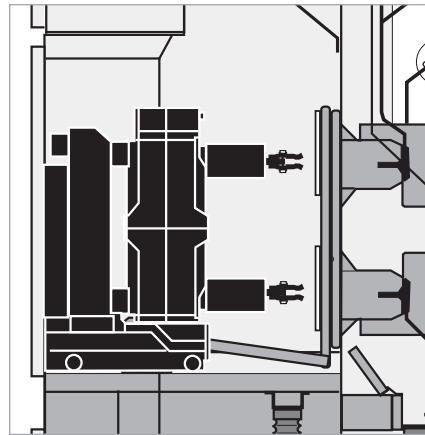

Fig. 36
Truck in disconnected position

Racking-in the truck for PIX High panels from disconnected into service position

1. Press the interlocking slide (Fig. 37, item 1) to the left and hold it. Insert crank through the opening in the door onto the drive shaft of the truck (2).
2. Turn crank clockwise until the position indicator above the crank indicates "I" (Fig. 37, item 3). Remove crank.
3. Check position of the truck (Fig. 38) through the inspection port.

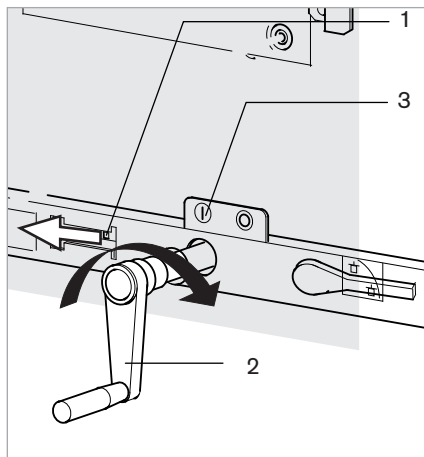

Fig. 37
1 Press interlocking slide to the left
2 Insert crank and turn it clockwise
3 Position indicator "I"

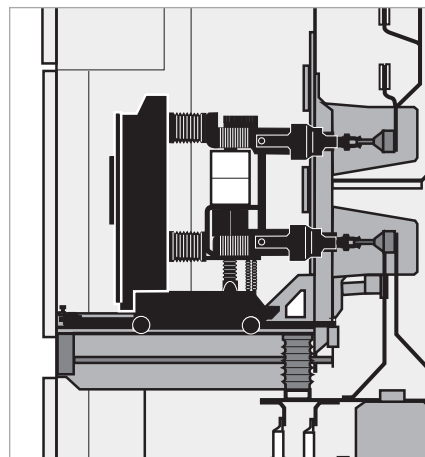

Fig. 38
Truck in service position

Racking-out the truck for PIX High panels from service into disconnected position

1. Press the interlocking slide (Fig. 39, item 1) to the left and hold it. Insert crank through the opening in the door onto the drive shaft of the truck (2).
2. Turn crank counter-clockwise until the position indicator above the crank indicates "O" (Fig. 39, item 3). Remove crank.
3. Check position of the truck (Fig. 40) through the inspection port.

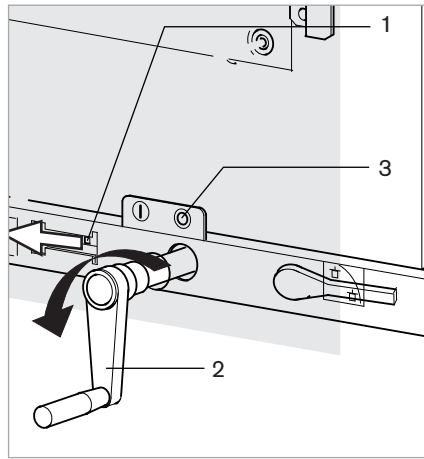

Fig. 39

- 1 Press interlocking slide to the left
- 2 Insert crank and turn it counter-clockwise
- 3 Position indicator: "O"

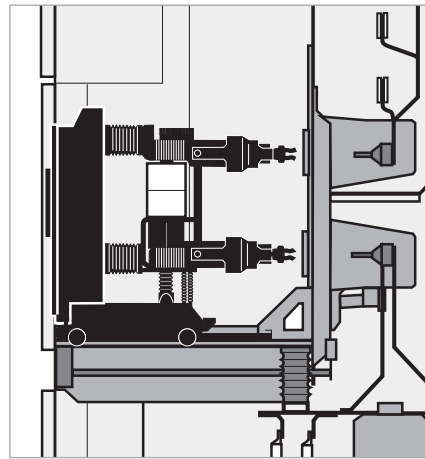

Fig. 40

Truck in disconnected position

Maintenance



Safety provisions

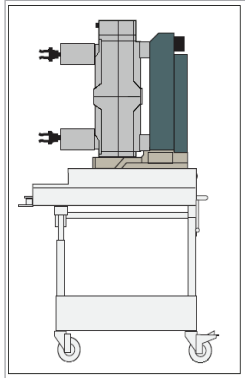

Fig. 41 Transport trolley

⚡ ⚠ DANGER

HAZARD OF ELECTRIC SHOCK, EXPLOSION, OR ARC FLASH

- Electrical equipment must only be maintained by qualified personnel.
- The circuit breaker must not be completely disassembled for maintenance work, except the accessories described in this maintenance section.

Failure to follow these instructions will result in death or serious injury.

Maintenance and maintenance work may only be performed by specialist electricians who have been certified by the manufacturer for EvoPact HVX vacuum circuit-breakers and who are familiar with the appropriate safety provisions. For inspection and maintenance the circuit breaker HVX-E have to be on the transport trolley.

Intervention levels

Different skill levels have been established to define the persons who are qualified to work on Medium-Voltage equipment.



End User

Level 1

Maintenance operations that can be carried out by actors with basic electrician skills doing operations according to instructions provided with the device by Schneider Electric (Open, Close, Racking-in/out...)



End User Schneider Electric's Partner Schneider Electric

Level 2

Preventive maintenance operations requiring simple procedures and / or support equipment that can be carried by professional electrical actors performing actions according to Schneider Electric documentation.



Schneider Electric's Partner Schneider Electric

Level 3

Preventive or curative maintenance operations that can be carried out by an authorized person performing actions delegated by Schneider Electric.



Schneider Electric

Level 4

Preventive or curative maintenance operations that may affect the device performances that can be carried out by Schneider Electric local entities, either in charge of adaptation or Services.

Recommended maintenance program

Preventive maintenance operations

⚠ CAUTION

HAZARD OF DEVICE DAMAGE

- Comply with specified maintenance intervals.
- Perform maintenance according to the actual operating and ambient conditions.
- Contact your Schneider Electric local representative or your equipment manufacturer for any queries.

Failure to follow this instruction can result in injury or equipment damage.

Different maintenance program must be carried out:

- Basic level of preventive maintenance
 - to be performed every year ^[1]
 - by level 1 and level 2.
- Advanced level of preventive maintenance
 - to be performed every two years ^[1]
 - by level 3.
- Exclusive level of preventive maintenance
 - to be performed every five years ^[1]
 - by level 4, using ProDiag Breaker diagnostic tool.

^[1] Recommended under normal operating conditions. However, this recommended frequency should be increased according to the level of criticality (low, major, critical) and the severity of environment conditions.

To define appropriate Maintenance program for your equipment, contact your Schneider Electric Maintenance Service local representative.

EvoPact HVX installed in normal service condition and with preventive maintenance program is designed up to:

Circuit breaker	Racking device	Charging motor	Auxiliary devices	Mechanical interlocks
10,000 operation cycles	1,000 operation cycles	10,000 operations	10,000 operations	2,000 operation cycles

Basic level preventive maintenance program to be performed every year

Basic level preventive maintenance tasks

Basic preventive maintenance corresponds to maintenance levels 1 and 2. Basic preventive maintenance tasks such as operational checks, as well as repairs by standard exchange of certain assemblies can be carried out by qualified customer personnel with basic training. There is no dismantling of parts of the circuit breaker.

Part	Check	Frequency: every year	Tools
Device	Check the general condition of the device (Cover, Frame, Poles, Racking device and Shutter Ramp, MV connection & Cluster, LV Connection)	■	
Mechanism	Operate (Open/Close) the device manually and electrically	■	
	Charge the device electrically and check the charging time	■	Power supply AC/DC Time measuring instrument
	Check the complete closing of the device poles	■	
	Check the number of operation cycles of device	■	
Breaking Device	Check the cleanliness of the device (Chair, Insulating cover, VI sleeve)	■	
Auxiliaries	Check auxiliary wiring and insulation	■	
Device Locking for Fixed Circuit Breaker	Operate device keylocking	■	
	Operate device padlocking	■	
Racking Device for Withdrawable Circuit Breaker	Check the device racking interlock (operation of the red opening pushbutton)	■	
	Check the Racking-In & Racking-Out position contacts	■	
	Check the operation of Shutter Ramp	■	
	Operate the racking device manually	■	
	Operate the racking device electrically for motorized circuit breaker	■	
	Check the number of racking operating cycles	■	
Racking Device Padlocking	Operate keylocking system	■	
	Operate padlocking system	■	

Cleaning insulating components

To ensure the specified insulating level, the insulating components must be clean. On principle, general cleanliness of the circuit-breaker and of its external parts should be ensured.

Slight contamination

Clean using a dry, lint-free cloth. Depending on the degree of soiling, replace cloth as often as necessary.

Severe soiling

Cleaning agent (see “Auxiliary products”, page 47) must be used for cleaning.

The use of other cleaning agents is not admissible.

- Wear protective gloves
- Use cleaning agent according to manufacturer’s instructions.
- Soak the cloth thoroughly and wipe the insulating components. Keep duration of exposure as short as possible.
- Expose the cleaned surface to the air for at least two hours.
- When cleaning, make sure that the lubrication in the drive mechanisms is not removed. If the drives are no longer sufficiently lubricated, replace the grease (see “Lubrication instructions”, page 44).

Avoiding condensation

To ensure the specified insulating level, the circuit-breaker – especially its insulating components – must not be exposed to condensation.

1. If condensation is detected, clean the circuit-breaker (see “Specifications for screw connections”, page 48) .
2. Check heating system or install a heating. It must provide a sufficient heating performance to prevent condensation on the circuit-breaker.
3. Condensation can also be prevented by ensuring suitable ventilation and heating of the station or by using de-humidification devices.

Corrosion protection

Drive mechanisms and covers have a long-term protection against corrosion. Any damage to the paint, scratches and other damage must be repaired immediately to avoid corrosion. Contact the manufacturer’s Service Center.

Replacement of components

Drive or live high-voltage components may be replaced as required.

The following data on the nameplate are relevant for replacement of components or in case of any queries (see also “Nameplate”, page 13):

- Type designation
- Serial number
- Year of construction

If you have any queries regarding replacement of components, please contact the manufacturer’s Service Center.

Lubrication instructions

NOTICE

HAZARD OF CIRCUIT BREAKER DAMAGE

- Do not wash out bearings and joints with cleaning agent.
- Do not lubricate the following elements:
 - Ball bearings
 - Auxiliary releases
 - Micro switches
 - Blocking coils
 - Position indicators
- Use only approved Mobilith SHC 100 grease (see «Auxiliary products», page 47).

Failure to follow this instruction can result in equipment damage.

Truck mechanism

- Spindle of truck mechanism (Fig. 42, item 1). The spindle is accessible from below.
- Geared wheels of truck mechanism (only in case of motor-drive) (Fig. 42, item 2). The geared wheels are accessible once the lower front cover has been removed.

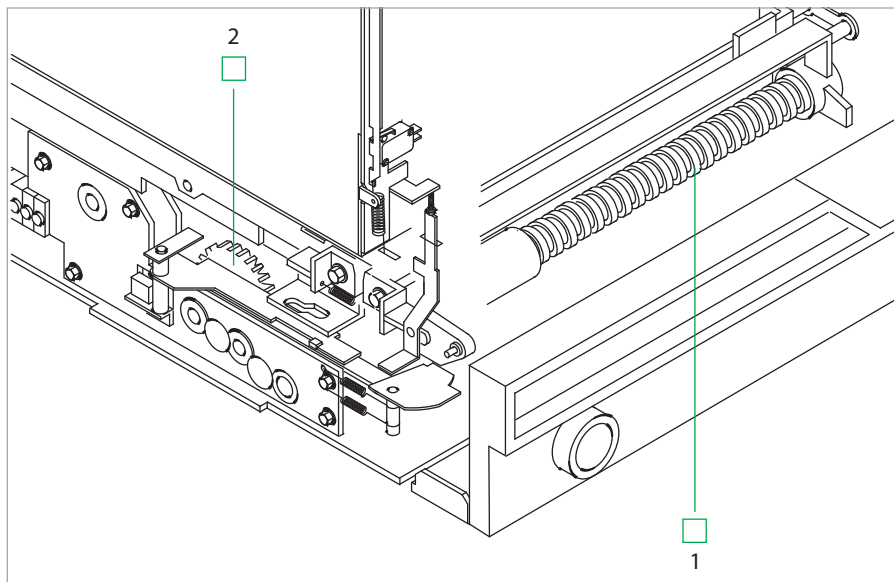

Fig. 42

Spindle of truck mechanism

□ Mobilith SHC 100 grease

1 Spindle

2 Geared wheels

Truck mechanism in the HVX-E for PIX High panels

To have access to the points of lubrication, make sure that the disconnecting truck is in service position.

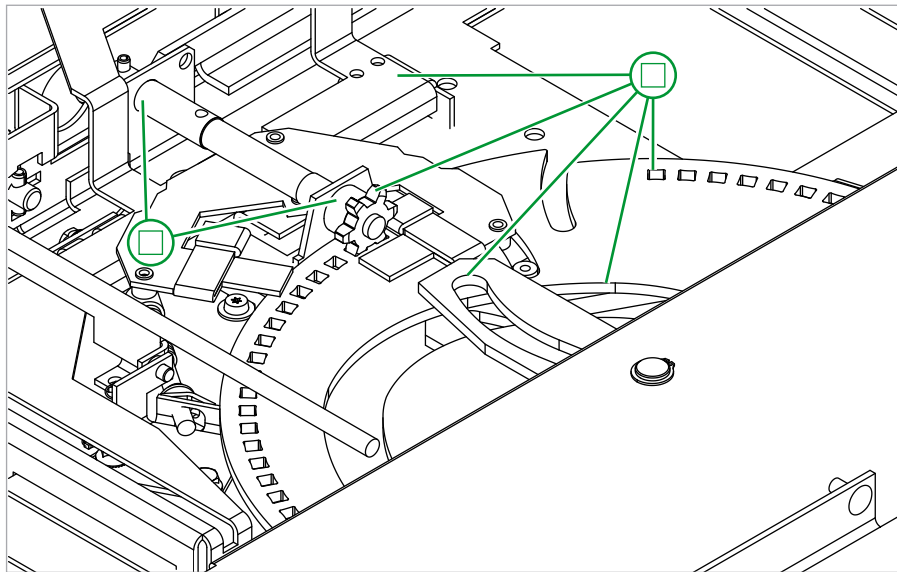

□ Mobilith SHC 100 grease

Moving contacts

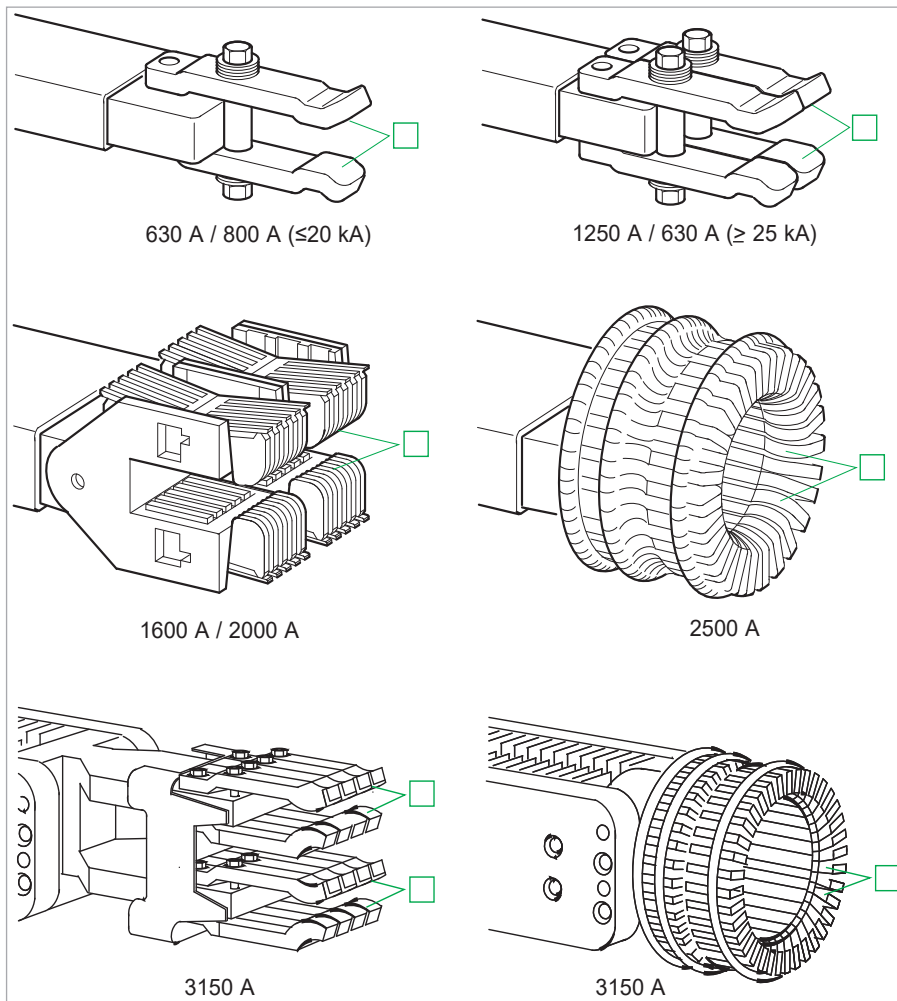

□ Mobilith SHC 100 grease

Circuit-breaker

Remove operating Interface:

Tools: TORX screwdriver, size T25 / slotted screwdriver

Remove the five M5 screws on the front and remove the operating panel.

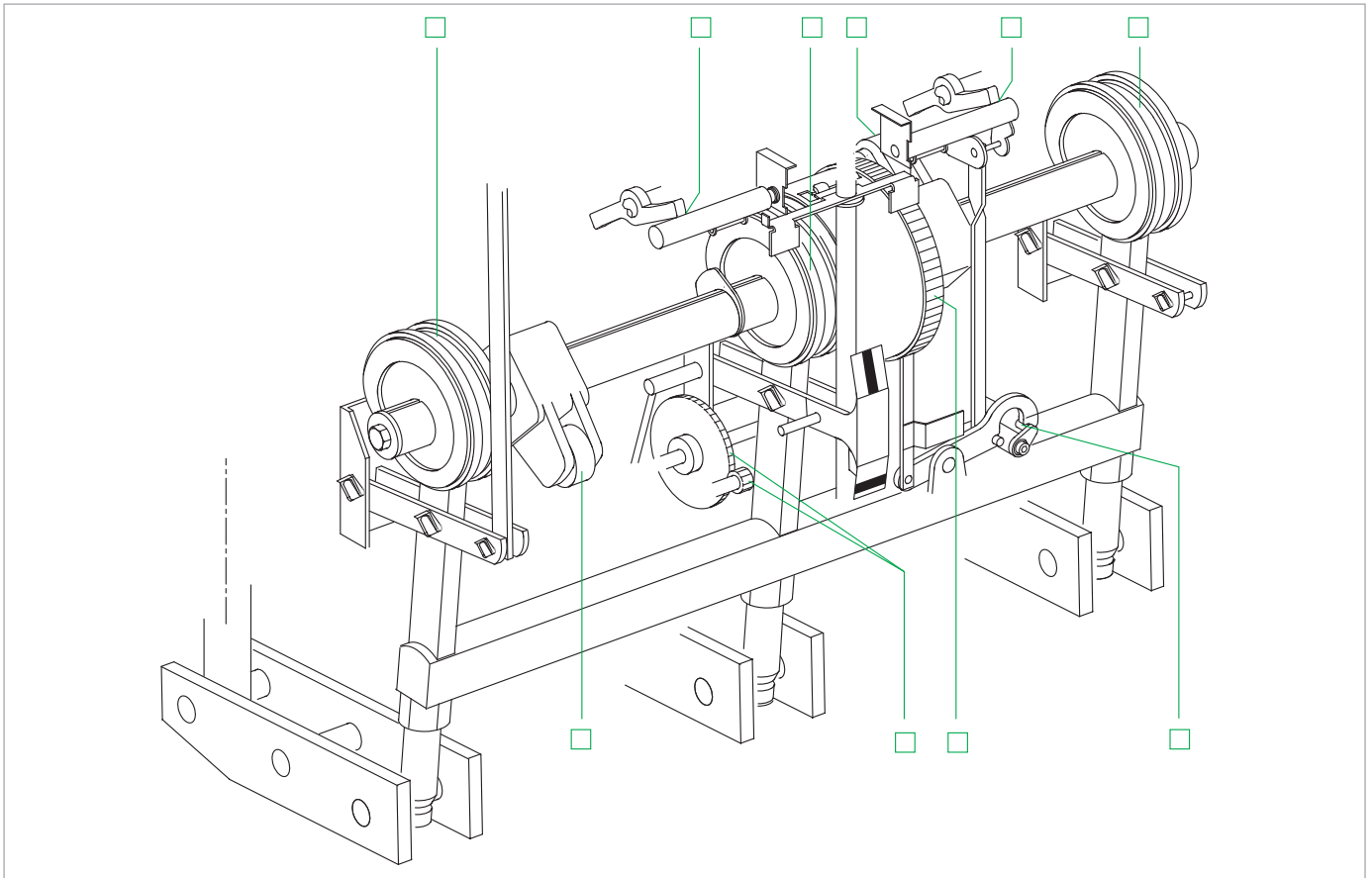

□ Mobilith SHC 100 grease

Final steps

Mount operating interface and insert circuit-breaker in panel (see Chapter "Assembly", page 18).
Check circuit-breaker in acc. with Chapter "Commissioning", page 29.

Annex



Auxiliary products

The auxiliary products are available from the manufacturer. The use of alternative auxiliary products is not permissible.

Designation	Reference
Cleaning agents	<ul style="list-style-type: none"> • SAEKA Cleaning Paste • Mould Release QZ 13
Grease	Mobilith SHC 100

Treatment of connected contact surfaces

NOTICE

HAZARD OF SWELLING OF THE HEAT-SHRINKABLE SLEEVES

Do not bring the heat-shrinkable sleeve into contact with the contact grease.

Failure to follow this instruction can result in equipment damage.

NOTICE

HAZARD OF ZINC AND PASSIVATION REMOVAL

Do not brush too heavily.

Failure to follow this instruction can result in equipment damage.

- Contact areas must be subjected to preliminary treatment before screw-fastening

Material of contact surfaces	Pre-treatment
Silver-plated	Cleaning
Copper or copper alloy	Clean, expose metallic surface
Steel	Clean, expose metallic surface
Zinc-plated steel	Clean, brush
Hot-galvanized sheet-metal	Clean, brush

- Immediately after the pre-treatment, coat the contact surfaces with contact grease.

Specifications for screw connections

General screw connections

Screw/bolt	Grade or material		
	Plastics	$\geq 8.8 \leq 10.9$	Self-locking screw ≥ 8.8
Thread Ø	Tightening torques [Nm]		
M 4	0.25	2.6	
M 5	0.5	5.0	7.0
M 6	0.8	8.8	12.3
M 8	1.8	21.0	30.0
M 10	3.5	42.0	59.0
M 12	6.0	70.0	97
M 16	12	170	
M 20		330	

Note: The maximum tolerance for the effective tightening torques is around 15%.

Screw fastening for power transmission

Screw connection for terminal strips

Screws and bolts: Grade ≥ 8.8

Conductor material: copper	
Thread Ø	Tightening torques [Nm]
M 6	6.5
M 8	17
M 10	35
M 12	68
M 16	135

Thread Ø	Tightening torques [Nm]
M 2.5 (M 2.6)	0.5
M 3	0.7
M 3.5	1.0
M 4	1.5
M 5	2.5

Schneider Electric

35, rue Joseph Monier
92500 Rueil-Malmaison - France
☎ +33 (0)141297000
www.schneider-electric.com

© Schneider Electric 2021

All rights reserved to this technical manual.

Reproduction and making available of this technical manual, or extracts, to third parties are prohibited. Only integral reproduction of this technical manual is permitted with the written permission from Schneider Electric.

Electronic copies in e.g. PDF-format or scanned version have the status "for information only".

The only valid version of this technical manual is always enclosed directly to the product in question by the factory.